

SPECIFICATIONS	
CONTACT CARRIER MATERIAL	TPU
CONTACT MATERIAL/PLATING	BRASS/GOLD
HOUSING MATERIAL/PLATING	BRASS/NICKEL
RATED CURRENT [A]	9.0 A
RATED VOLTAGE [V]	600 V
TEMPERATURE RATING	-40°C to +105°C (-40°F to +221°F)
PROTECTION CLASS	MEETS NEMA 1,3,4 AND IEC IP67
ACCOMODATES WALL THICKNESS	.040" (1.0 mm) to .875" (22.2 mm)
GASKET MATERIAL	BUNA N

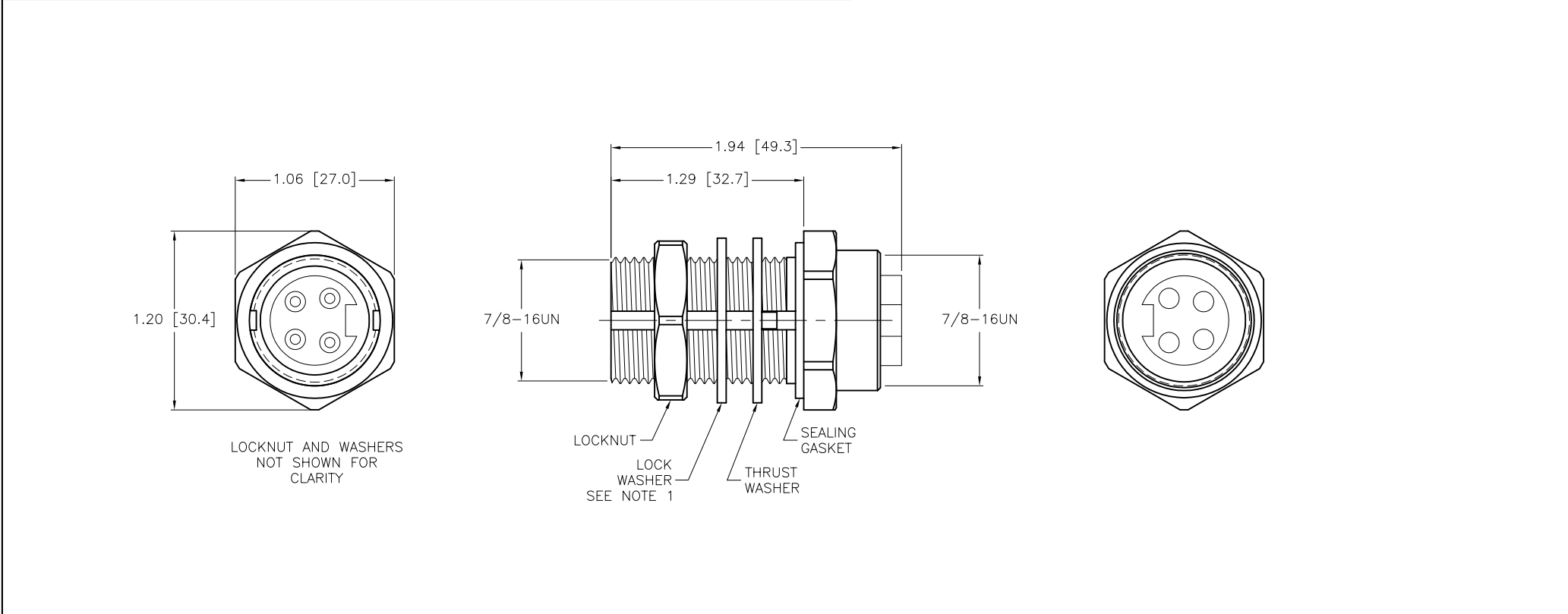

SOURCE DRAWING - FOR REFERENCE ONLY

NOTE(S):
1. LOCK WASHER TO BE INSTALLED ON THREADS AS SHOWN.

RELATED DOCUMENTS		3RD ANGLE PROJECTION		THIS DRAWING IS CONFIDENTIAL AND THE PROPERTY OF TURCK INC. USE OF THIS DOCUMENT WITHOUT WRITTEN PERMISSION IS PROHIBITED.		TURCK INC High Technology Sensors and Automation Controls 3000 CAMPUS DRIVE MINNEAPOLIS, MN 55441 1-800-544-7769 (763) 553-7300 (763) 553-0708 fax turck.com			
1.			ALL DIMENSIONS DISPLAYED ON THIS DRAWING ARE FOR REFERENCE ONLY	DRFT	IK	DATE	7/21/98		
2.				APVD		SCALE	1=1.0	DESCRIPTION	RSF RKF 40/22
3.				UNIT OF MEASUREMENT			IDENTIFICATION NO.	REV	
4.				INCH [MILLIMETER]			U2309-47	D	
MATERIAL		SEE SPECIFICATIONS		CONTACT TURCK FOR MORE INFORMATION		DO NOT SCALE THIS DRAWING		FILE: U2309-47	SHEET 1 OF 1
FINISH		SEE SPECIFICATIONS							

D	DRAWING PROCESSED AS PART OF ECO 38872	KMY	05/10/12	38872
REV	DESCRIPTION	BY	DATE	ECO NO.