



Motor protective circuit
breaker
SM1P

Product designation

Product type designation

Electrical features

Number of poles	nr.	3
Magnetic protection		yes
Thermal protection		yes
Phase failure detection		yes
Rated insulation voltage U_i IEC/EN	V	690
Rated impulse withstand voltage U_{imp}	kV	6
Rated frequency	Hz	50/60
Thermal trip adjustment range		0.1...0.16
Rated current (I_n)	A	0.16
Magnetic tripping		10 x I_n
Total power dissipation	W	2.07

Operational short-circuit current breaking capacity (I_{cs}) at AC

230V	kA	100
400V	kA	100
440V	kA	100
500V	kA	100
690V	kA	100

Maximum short-circuit current breaking capacity (I_{cu}) at AC

230V	kA	100
400V	kA	100
440V	kA	100
500V	kA	100
690V	kA	100

Tripping class

10A

IEC Utilization category

A

Operations

Mechanical life	cycles	100000
Electrical life	cycles	100000

Mechanical features

Tightening torque for terminals

min	Nm	2.5
max	Nm	3
min	lbin	1.8
max	lbin	2.2

Max number of wires simultaneously connectable

nr. 2

Conductor section

AWG/Kcmil

min	16
max	8

Flexible w/o lug conductor section

min	mm ²	1
-----	-----------------	---

Flexible c/w lug conductor section

min	mm ²	1
-----	-----------------	---

Flexible with insulated spade lug conductor section

min	mm ²	1
-----	-----------------	---

Screwdriver

PH2

Power terminal protection according to IEC/EN 60529

IP20

Cable stripping length

main circuit mm 1

Ambient conditions

Temperature

Operating temperature

min	°C	-20
max	°C	60

Storage temperature

min	°C	-50
max	°C	80

Compensation temperature

min	°C	-20
max	°C	50

Max altitude

m 3000

Operating position	normal allowable		Vertical plan Any
Fixing			Screw / DIN rail 35mm
Weight		g	280
UL technical data			
UL508 / UL60947-4-1 Manual Motor Controller - Short circuit current			
Motor Disconnect	at 240V at 480V at 600V protection	kA kA kA	50 50 50 Fuse or CB
Group Motor Installation			
	at 240V at 480V at 600V protection	kA kA kA	50 50 50 Fuse or CB
Tap Conductor Protection			
	at 480Y/277V at 600Y/347V	kA kA	50 50
UL508 / UL 60947-4-1 Manual Self Protected Combination Motor Controller (Type E) Short circuit current			
	UL508 / UL 60947-4-1 Manual Self Protected Combination Motor Controller (Type E) Short-circuit cur	50	
	UL508 / UL 60947-4-1 Manual Self Protected Combination Motor Controller (Type E) Short-circuit cur	50	
	UL508 / UL 60947-4-1 Manual Self Protected Combination Motor Controller (Type E) Short-circuit cur	50	
Maximum UL/CSA horsepower ratings single-phase			
	at 110V-120V at 220V-240V	hp hp	- -
Maximum UL/CSA horsepower ratings three-phase, 3-pole			
	at 200V-208V at 220V-240V at 440V-480V at 550V-600V	hp hp hp hp	- - - -

Dimensions

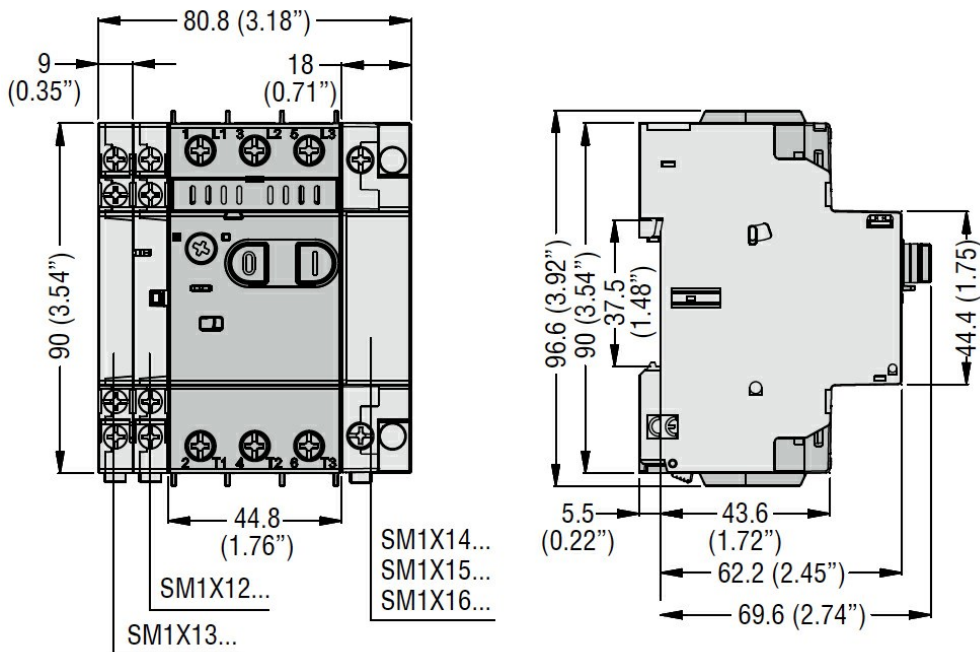

Wiring diagrams

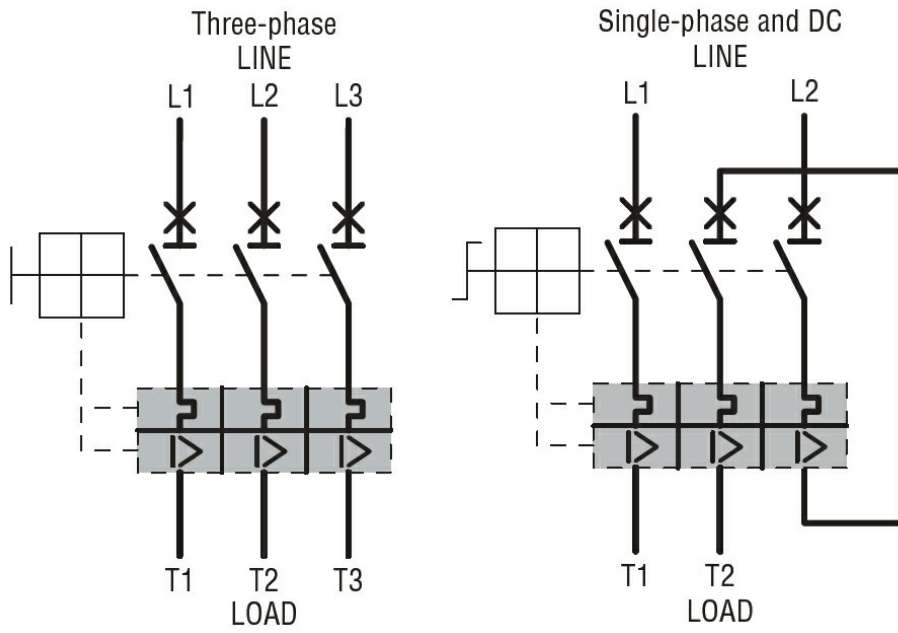

Certifications and compliance

Certifications

CSA C22.2 n° 14
IEC/EN 60947-1
IEC/EN 60947-2
IEC/EN 60947-4-1
UL508

Compliance

cULus
EAC

ETIM 6 classification