

BA Series



Key features of the BA series include:

- Self-contained: end plates are not required
- Rugged heavy-duty construction
- Current capacities up to 40A
- 3-pole units available as 1 piece (no endplates are needed)
- Fuse blocks with blown fuse indicators



Specifications

Power Blocks



		Part Numbers	BA111T	BA211T	BA311T	BA411S	
Specifications	Appearance						
	Width		0.984" (25mm)	1.201" (30.5mm)	1.358" (34.5mm)	0.630" (16mm)	
	Approvals		UL, CSA	UL, CSA	UL, CSA	UL, CSA	
	No. of Poles		3	3	3	1	
	Wire Sizes		22 to 14 AWG (2mm ²)	22 to 12 AWG (3.5mm ²)	18 to 10 AWG (5.5mm ²)	16 to 6 AWG (14mm ²)	
	Voltage/Current	UL/CSA		300V / 15A	300V / 20A	150V / 30A	600V / 40A
		JIS		600V / 16A	600V / 21A	600V / 40A	600V / 70A
	Terminals	Size		M3	M3.5	M4	M5
		Type		Standard screw	Standard screw	Standard screw	Standard screw
	Mounting			35mm DIN rail	35mm DIN rail	35mm DIN rail	35mm DIN rail
Terminal Torque	(N-m)		0.6 - 1.0	1.0 - 1.3	1.4 - 2.0	2.6 - 3.7	
	(in-lbs.)		5.3 - 8.9	8.9 - 11.5	12.4 - 17.8	23.1 - 32.8	
DIN Rail Stop			BNL-5	BNL-5	BNL-5	BNL-5	
Dust Cover			BNC220	BNC220	BNC230	BNC320	
Marking Strip	PVC		BNM7	BNM7	BNM7	BNM7	
	Fiberglass		BNM9	BNM9	BNM9	BNM9	
	End clip		BNM3	BNM3	BNM3	BNM3	



1. BNDN1000 aluminum DIN rails are available in 1 meter lengths.
2. Marking strips are available in 1 meter lengths.

Specifications con't

Fuse Blocks

		Part Numbers	BAF111SU	BAF111SNU	BAF111SDU
Specifications	Appearance				
	Width		0.630" (16mm)	0.630" (16mm)	0.630" (16mm)
	Blown Fuse Indicator		None	Neon (100 to 300V AC)	LED (24V DC)
	Approvals		UL, CSA	UL, CSA	UL, CSA
	No. of Poles		1	1	1
	Wire Sizes		18 to 10 AWG (5.5mm ²)	18 to 10 AWG (5.5mm ²)	18 to 10 AWG (5.5mm ²)
	Current		10A maximum	10A maximum	10A maximum
	Terminals	Size	M4	M4	M4
		Type	Standard screw	Standard screw	Standard screw
	Mounting		35mm DIN rail	35mm DIN rail	35mm DIN rail
	Terminal Torque	(N-m)	1.4 - 2.0	1.4 - 2.0	1.4 - 2.0
		(in-lbs.)	12.4 - 17.8	12.4 - 17.8	12.4 - 17.8
	DIN Rail Stop		BNL-5	BNL-5	BNL-5
	Dust Cover		—	—	—
Marking Strip		BNM7	BNM7	BNM7	
Applicable Fuse Size		1/4" x 1-1/4" (6.35 x 31.8mm)	1/4" x 1-1/4" (6.35 x 31.8mm)	1/4" x 1-1/4" (6.35 x 31.8mm)	



BNDN1000 aluminum DIN rails are available in 1 meter lengths.





Dimensions

Part No.	Diagram
BA111T	
BA211T	
BA311T	

Part No.	Diagrams
BA411S	
BAF111	

Accessories







Part Numbers: End Plates, DIN Rail Stops, Stand-Offs, DIN Rail and Dust Covers

Description	Appearance	Use with	Part No.	Remarks
End Plates		BNH10W BNH15MW BNH15LW	BNE15W	
		BNH30W	BNE30W	
		BNF10SW BNF10NW BNF10DW	BNE20	
		BNH50W	BNE50W	
		BN75W	BNE75W	
		BN150W	BNE150W	
		BNDH15W	BNDE15W	
DIN Rail Stops		BNH10W BNH15MW BNH15LW BNH30W BNH50W BNF10SW BNF10NW BNF10DW BA111T BA211T BA311T BA411S BAF111SU BAF111SDU	BNL5 (small)	<ol style="list-style-type: none"> DIN rail stops prevent side-to-side movement. The BNL-5 width is 0.375" (9.5mm).
		BN75W BN150W	BNL6 (medium)	<ol style="list-style-type: none"> DIN rail stops prevent side-to-side movement. The BNL-6 width is 0.375" (9.5mm). To firmly stabilize these higher profile terminal blocks, the BNL-6 has a higher profile than the BNL-5.
		BNDH15W BN200NW# BN400NW#	BNL8 (large)	<ol style="list-style-type: none"> DIN rail stops prevent side-to-side movement. The BNL-8 width is 0.571" (14.5mm). # = number of poles.
DIN Rail Stand-Offs		All series	BNS3	1.46" (37mm) height
			BNS4	3.03" (77mm) height
DIN Rail		All series	BNDN1000 (length 39.37" (1m))	<ol style="list-style-type: none"> For calculating the rail lengths required, see the instructions on page P-18. The DIN rail material is aluminum.
Dust Covers		BNDH15W BNH10W BNH15MW BNH15LW BNH30W	BNC230	The overall length is 39.37" (1,000mm). The material is polycarbonate.
		BNH50W	BNC320	
		BN75W	BNC420	
		BN150W	BNC520	
		BN200	BAC820	
		BN400	BNC1000	

P
Terminal Blocks

Accessories con't

Part Numbers: Rods, Nuts, Marking Strips, Dust Covers, and Jumpers

Description	Appearance	Use with	Part No.	Remarks
Marking Strips		All series	BNM7	Material: polyvinyl chloride (PVC) Strip dimensions are 0.37"x39" (9.5 x 1,000mm).
			BNM9	Material: fiberglass Strip dimensions are 0.37"x39" (9.5 x 1,000mm).
Marking Strip Fastener		All series	BNM3	Used to prevent marking strips from sliding out.
Ring Terminal Jumpers		BNH10W	BNJ16	Jumpers come standard with 6 points. Note: insulated jumpers available - add "B" to end of part number. For example, BNJ26WB.
		BNH15MW	BNJ26W	
		BNH15LW	BNJ46	
		BNH30W	BNJ56	
		BNDH15W	BNJ26W	
Fork Terminal Jumpers		BNH10W	BNJ16F	Jumpers come standard with 6 points. Note: insulated jumpers available - add "B" to end of part number. For example, BNJ26WB.
		BNH15MW	BNJ26FW	
		BNH15LW	BNJ46F	
		BNH30W	BNJ56F	
		BNDH15W	BNJ26FW	
Surface Mount Bracket		BNDH15W (dual-deck)	BNDL2	Used to surface mount dual-deck terminal blocks. (BNDL2).
M4 Thread Rod		BNDH15W	BNR1 (265mm)	1. Rod and connecting nuts are used to mount dual-decks collectively. 2. Each connecting nut set includes 1 hex connecting nut and 1 round connecting nut.
			BNR2 (500mm)	
Connecting Nuts		BNR1 BNR2	BNN1	3. The BNR1 rod dimensions are 0.027" x 10.43" (0.7 x 265mm). 4. The BNR2 rod dimensions are 0.027" x 19.69" (0.7 x 500mm).



For accessory dimensions, see page P-14.

P

Terminal Blocks

Dimensions

Dimensions: DIN Rail

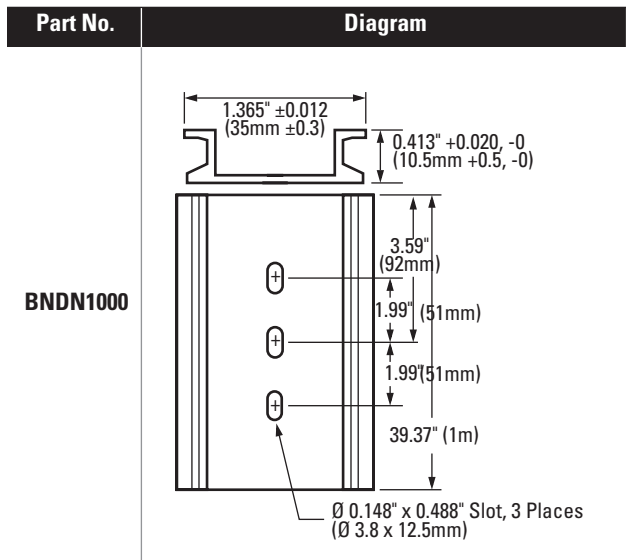

Dimensions: Jumpers

Part No.	Diagram	Dimensions						
		A	B	C	D	E*	F	G
BNJ16	<p>Part No. with "F" = Fork</p>	0.156" (4mm)	0.433" (11mm)	0.224" (6mm)	0.146" (4mm)	0.276" (7mm)	1.365" (35mm)	—
BNJ16F (fork)		0.433" (11mm)	0.144" (3.7mm)	0.224" (6mm)	0.146" (4mm)	0.276" (7mm)	1.365" (35mm)	0.156" (4mm)
BNJ26W		0.175" (4.5mm)	0.429" (11mm)	0.25" (6.4mm)	$\varnothing 0.144''$ (3.7mm)	0.312" (8mm)	1.56" (40mm)	—
BNJ26FW (fork)		0.429" (11mm)	0.175" (4.5mm)	0.25" (6.4mm)	$\varnothing 0.144''$ (3.7mm)	0.312" (8mm)	1.56" (40mm)	0.175" (4.5mm)
BNJ46		0.215" (5.5mm)	0.429" (11mm)	0.32" (8.2mm)	$\varnothing 0.165''$ (4.2mm)	0.41" (10.5mm)	2.048" (52.5mm)	—
BNJ46F (fork)		0.429" (11mm)	0.175" (4.5mm)	0.32" (8.2mm)	$\varnothing 0.165''$ (4.2mm)	0.41" (10.5mm)	2.048" (52.5mm)	0.215" (5.5mm)
BNJ56		0.234" (6mm)	0.371" (9.5mm)	0.363" (9.3mm)	$\varnothing 0.164''$ (4.2mm)	0.468" (12mm)	2.34" (60mm)	—
BNJ56F (fork)		0.371" (9.5mm)	0.228" (5.8mm)	0.363" (9.3mm)	$\varnothing 0.164''$ (4.2mm)	0.468" (12mm)	2.34" (60mm)	0.234" (6mm)



- * Dimension E on center.
- Thickness + 0.8mm (0.0315").

Dimensions (con't)

Dimensions: DIN Rail Stops and Stand-Offs

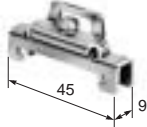
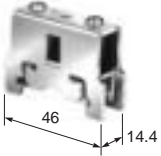
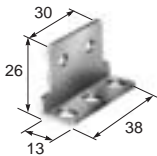
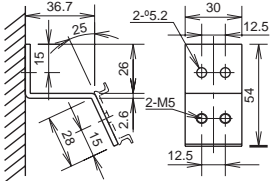
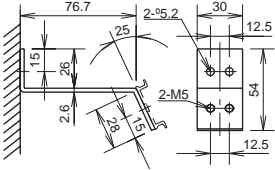
Part No.	Dimensions
BNL-5	
BNL-6	
BNL-6 shown, BNL-5 same except without back crossbar	
BNL-8	
BNDL2	
BNS3	
BNS4	

Dimensions (con't)

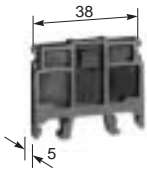
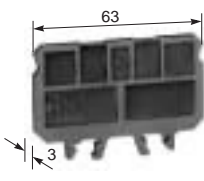
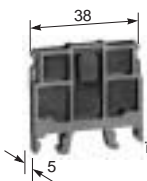
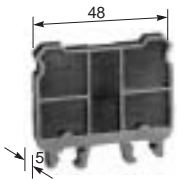

Dimensions: End Plates

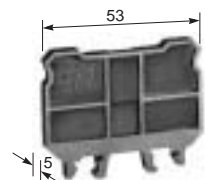
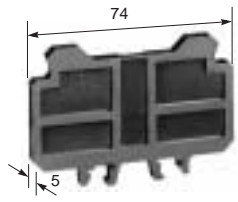
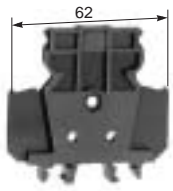
Part No.	Dimensions
BNE15W	
BNE20	
BNE30W	
BNE50W	

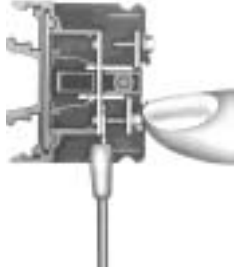

Part No.	Dimensions
BNE75W	
BNE150W	
BNDE15W	

Instructions

Wiring Touch-Down Terminal Blocks: BNH Series

Instructions	Step 1	Step 2	Step 3	Step 4
Step 1. Insert the wire (or crimping terminal) into the terminal block with the terminal screws in the open position. (Use of crimping terminals is optional.)				
Step 2. Push the terminal screw down to hold the wire in place.				
Step 3. Hold the terminal screw down, and tighten with a screwdriver.				
Step 4. To remove the wire, loosen the terminal screw and pull up until wire is released.				

Installation and Removal of Terminal Blocks

Instructions	Appearance
<p>Step 1. Slide the terminal blocks onto the DIN rail from one end.</p> <p>Step 2. Use BNL5 or BNL6 end clips to secure the terminal block row and to prevent side-to-side movement. BNH10W, BNH15MW, BNH15LW, and BNH30W can be installed from the middle of a DIN rail.</p> <p>Step 3. To install, place the terminal block on top of the DIN rail and push down until both edges of the terminal block snap onto the DIN rail.</p> <p>Step 4. To remove the terminal block, use the BND2 removal tool as shown on the right.</p>	  <p>Removal Tool BND2</p>

Mounting Double-Deck Terminal Blocks

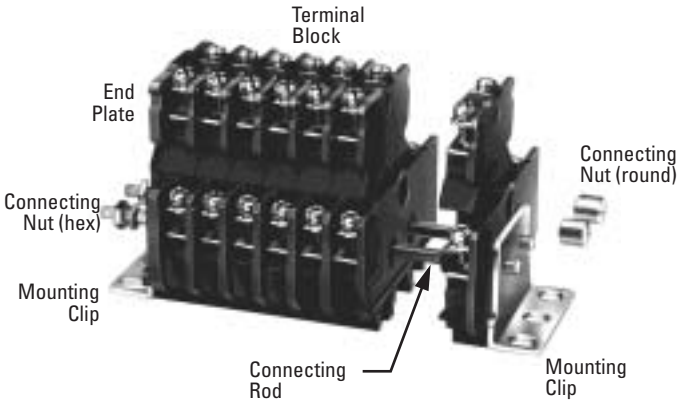
Instructions	Appearance
<p>DIN Rail Mount:</p> <p>Step 1. First install the end plate. Then mount the terminal blocks onto the DIN rail.</p> <p>Step 2. To prevent side-to-side movement on the DIN rail, use the BNL-8 mounting clip at both ends of the rail.</p>	
<p>Panel Mount:</p> <p>Step 1. Assemble a row of terminal blocks with end plates on exposed end(s).</p> <p>Step 2. Use BNDL2 mounting clips at both ends of a row.</p> <p>Step 3. With the two holes of the mounting clip aligned with the terminal block holes, insert a connecting rod through each hole.</p> <p>Step 4. Secure the ends of the connecting rods with the connecting nuts, as shown below.</p>	

Calculating DIN Rail Lengths

Instructions	Appearance
<p>Step 1. Add widths of all terminal blocks (reference pages K-4 through K-9).</p> <p>Step 2. Add the endplate thickness (usually only one).</p> <p>Step 3. Add the DIN rail stop widths (usually two are used).</p> <p>Step 4. Round to the nearest 2" (50mm) increment to allow for DIN rail hole spacing.</p> <p>Step 5. Add 1" (25mm) to ensure 0.5" (12.5mm) of clearance at each end of the DIN rail.</p>	

DIN Rail Stop Dimensions

Part No.	Width
BNL-5	.374" (9.5mm)
BNL-6	.374" (9.5mm)
BNL-8	.571" (14.5mm)

Torque Specifications

Screw Size	M3	M3.5	M4	M5	M6	M8	M10	M12	Diagram
Torque	(N-m) 0.6 to 1.0	1.0 to 1.3	1.4 to 2.0	2.6 to 3.7	3.9 to 5.4	10 to 13.5	21 to 28	38 to 49	
	(kgf-cm) 6.1 to 10.2	10.2 to 13.3	14.3 to 20.4	26.5 to 37.7	39.8 to 55.1	102 to 138	214 to 286	388 to 500	
Dimension A	0.257" (6.6mm)	0.332" (8.5mm)	0.371" (9.5mm)	0.499" (12.8mm)	0.655" (16.8mm)	0.890" (22.8mm)	1.279" (32.8mm)	1.981" (50.8mm)	
Dimension B	0.129" (3.3mm)	0.156" (4mm)	0.176" (4.5mm)	0.176" (4.5mm)	0.234" (6mm)	0.312" (8mm)	0.429" (11mm)	0.546" (14mm)	
Dimension C	0.195" (5mm)	0.195" (5mm)	0.234" (6mm)	0.254" (6.5mm)	0.332" (8.5mm)	0.429" (11mm)	0.624" (16mm)	1.014" (26mm)	
Dimension D	Ø 0.125" (3.2mm)	Ø 0.140" (3.6mm)	Ø 0.164" (4.2mm)	Ø 0.203" (5.2mm)	Ø 0.242" (6.2mm)	Ø 0.332" (8.5mm)	Ø 0.410" (10.5mm)	Ø 0.488" (12.5mm)	

Rated Current

Applicable Wire	Rated at 60°C
22 AWG (0.3mm ²)	3A
20 AWG (0.5mm ²)	5A
18 AWG (0.75mm ²)	7A
16 AWG (1.25mm ²)	10A
14 AWG (2mm ²)	15A
12 (3.5mm ²)	20A
10 (5.5mm ²)	30A
6 (14mm ²)	50A
4 (22mm ²)	75A
0 (38mm ²)	100A
00 (60mm ²)	150A
0000 (100mm ²)	200A
300mcm (150mm ²)	300A
400mcm (200mm ²)	350A

UL/CSA ratings are specified. The current carrying capacity depends on the rating of the wire used, as shown.



P
Terminal Blocks