

# › GNRS Smart Module Series

## Essential Solid State Relays

### DIN Rail - Module for GNR/GNR+

- › Current range from 2 to 40 A
- › Open Loads, Mains detection (and Partial Load break)
- › Under and Over current detection
- › Current teaching function
- › 3 LED Status indicator
- › IP20 touch-safe housing
- › Spring Connector (84050043N)



84050040N  
Current Monitoring



84050043N  
Current Detection & Diagnostic

Product Selection		
Rated Load Current	40A	
	32 V <sub>~</sub>	24-45 V <sub>~</sub>
Control Voltage		
4-32 V <sub>~</sub>	84050040N	
24-45 V <sub>~</sub>		84050043N

## PART NUMBERING SYSTEM

**Series**  
840: Single Phase

**Default**  
0: N/A

**Default**  
0: N/A

**Input Voltage**  
0: 4-32 V<sub>~</sub>  
3: 24-45 V<sub>~</sub>

840

5

0

0

4

1

N

**Mounting Type**  
5: DIN Rail

**Output Current**  
4: 40 A

**Generation**  
N: New Generation



**GNR Smart  
Module**

- ✓ Applications where loads are switched frequently (ex: thermoset molding)
- ✓ **To detect** load failures, blown fuses, heat zones status, as well as damaged and interrupted SSRs

Do you need an adapted or customized solution? Contact us on [www.crouzet.com](http://www.crouzet.com)

#### Description:

Crouzet Solid State Relays are designed to be used in almost any application, offering very long life expectancy and are easy to install, easy to use, robust and multipurpose.

For more information about Crouzet's Solid State relays, please visit [www.crouzet.com](http://www.crouzet.com).

Power Supply Specifications		
Description	40A	
Supply voltage range	8-30 V <sub>DC</sub>	24-45 V <sub>DC</sub>
Nominal Supply current	20 mA	

Input Specifications		
Description	4-32 V <sub>DC</sub>	24-45 V <sub>DC</sub>
Minimum Input Current	0.3 mA	1 mA
Maximum Input Current	20 mA	
Maximum Turn-On Time (Ton)	15 ms	
Maximum Turn-Off Time (Toff)	15 ms	

External Teach Specification		
Description	40A	
External Teach Voltage Range	4-32 V <sub>DC</sub>	24-45 V <sub>DC</sub>
Minimum Input Current	0.3 mA	1.4 mA
Maximum Input Current	3 mA	3.7 mA

Current sensing Specifications	
Description	40A
Maximum Teach Current	40 A
Minimum Teach Current	2 A
Undercurrent Detection	Teach Current * 0.84 Arms
Overcurrent Detection (84050043N)	Teach Current * 1.16 Arms
Load Voltage Frequency Range	15-200 Hz
Load Voltage Range	Din Rail SSR voltage range
Number of Loads	1 to 5

General Specifications	
Description	40A
Max. Turn Off time @ 50 Hz	15 ms
Max. Turn On time @ 50 Hz	15 ms
Ambient Operating Temperature Range	-40 °C to +80 °C
Ambient Storage Temperature Range	-40 °C to +100 °C
Weight (typical)	75 g
Housing Material	UL94 V-0
Humidity	40 to 85 %
LED Input Status Indicator	See LED Chart

Alarm Specifications		
Description	40A	
Output Voltage Range	4-32 V <sub>DC</sub>	24-45 V <sub>DC</sub>
Typical ON-state resistance	1 Ω	
Maximum Output Current	100 mA	
Minimum Output Current	3 mA	
Maximum Number of Outputs Connected in Parallel	Up to 5	
Alarm Delay	See LED Statut chart	
No Mains Voltage/Open Load	40 ms	
Detection Current Min/Max	0.5 A	

**General Notes**

(1)All parameters at 25 °C unless otherwise specified

**Diagrams**

**Wiring**

GNRS Smart

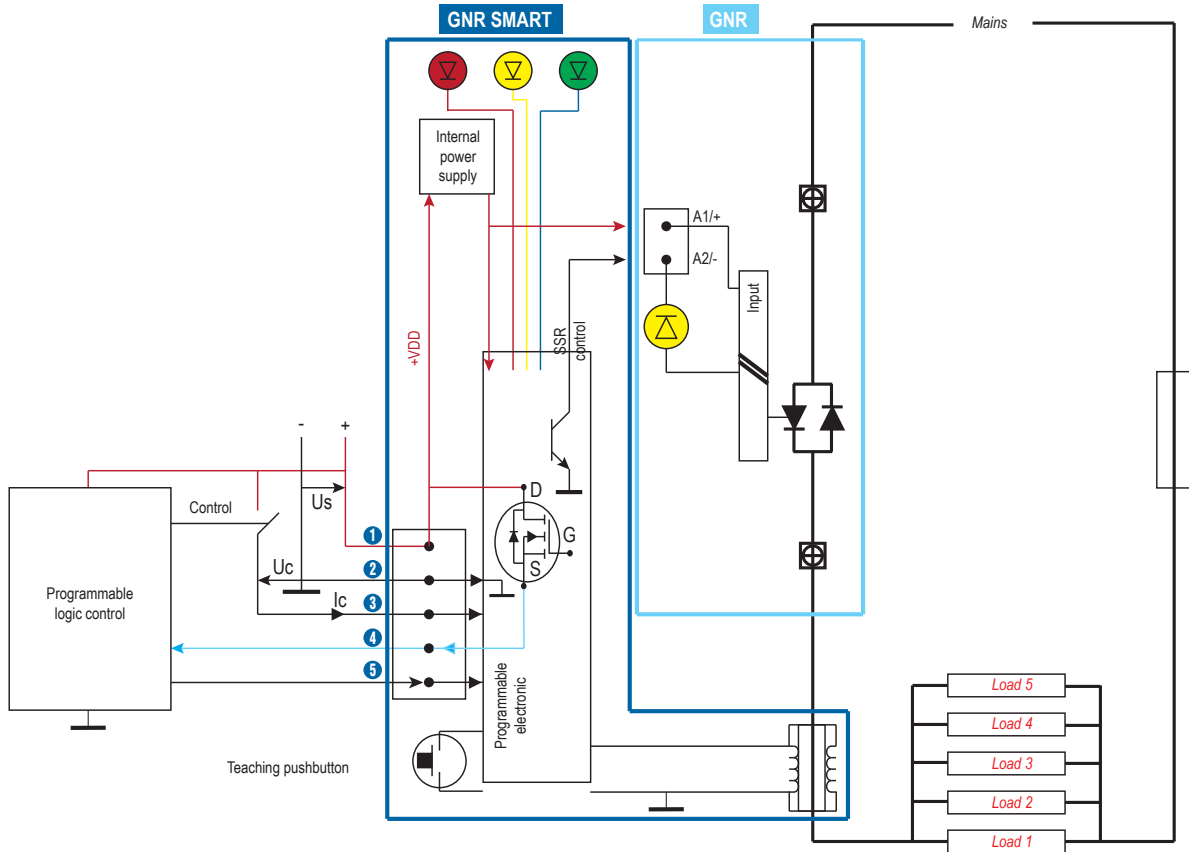

**GNRS**

- 1 Supply +
- 2 Supply -
- 3 Control input
- 4 Diagnostic output
- 5 External teach input

**Diagrams**

**Status Chart**

LED Status 84050040N

STATUS	LED INDICATOR				
	Alarm	ON	INPUT	Load Current	Diagnostic OUTPUT
No power	<input type="checkbox"/>	<input type="checkbox"/>	<input type="checkbox"/>	0A	Open (0V)
Normal Operation	<input type="checkbox"/>	<input checked="" type="checkbox"/>	<input checked="" type="checkbox"/>	=Iteach	Open (0V)
Open Mains / Load Blowed fuses	<input checked="" type="checkbox"/>	<input type="checkbox"/>	<input checked="" type="checkbox"/>	0A	Ton=100 ms Toff=100 ms
Short Circuit	<input checked="" type="checkbox"/>	<input checked="" type="checkbox"/>	<input type="checkbox"/>	0A	Closed (+VDD)
Partial Load Break	<input checked="" type="checkbox"/>	<input checked="" type="checkbox"/>	<input checked="" type="checkbox"/>	<Iteach*0.84	Closed (+VDD) Ton=1 s Toff=1s
Test / Teach Mode	<input type="checkbox"/>	<input checked="" type="checkbox"/>	<input checked="" type="checkbox"/>		
Teach Value Storing	<input type="checkbox"/>	<input checked="" type="checkbox"/>	<input checked="" type="checkbox"/>		

LED Status 84050043N

STATUS	LED INDICATOR				
	Alarm	ON	Input	Load Current	Diagnostic Output
No power	<input type="checkbox"/>	<input type="checkbox"/>	<input type="checkbox"/>	0A	Closed (+VDD)
Normal Operation	<input type="checkbox"/>	<input checked="" type="checkbox"/>	<input checked="" type="checkbox"/>	=Iteach	Closed (+VDD)
Open Mains / Load Blowed fuses	<input checked="" type="checkbox"/>	<input type="checkbox"/>	<input checked="" type="checkbox"/>	0A	Ton=2s Toff=1s
Short Circuit SSR	<input checked="" type="checkbox"/>	<input checked="" type="checkbox"/>	<input type="checkbox"/>	0A	Ton=1s Toff=1s
Over Load	<input checked="" type="checkbox"/>	<input checked="" type="checkbox"/>	<input checked="" type="checkbox"/>	>Iteach*1.16	Ton=200ms Toff=200ms
Partial Load Break	<input checked="" type="checkbox"/>	<input checked="" type="checkbox"/>	<input checked="" type="checkbox"/>	<Iteach*0.84	Ton=200ms Toff=2s
Test / Teach Mode	<input type="checkbox"/>	<input checked="" type="checkbox"/>	<input checked="" type="checkbox"/>		
Teach Value Storing	<input type="checkbox"/>	<input checked="" type="checkbox"/>	<input checked="" type="checkbox"/>		

Diagrams

Dimensions (mm)

GNR Smart module front view

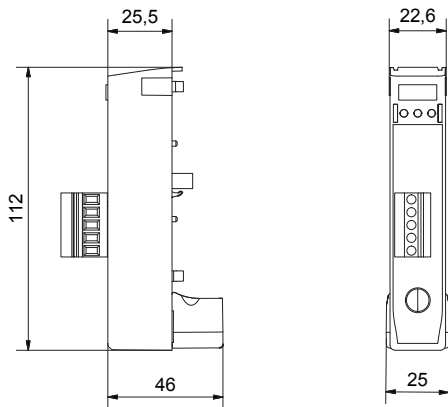

GNR Smart module side view

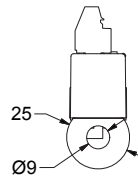

\*

Curves

Standard regulated input current vs Input Voltage

GNR Smart - 84050040N

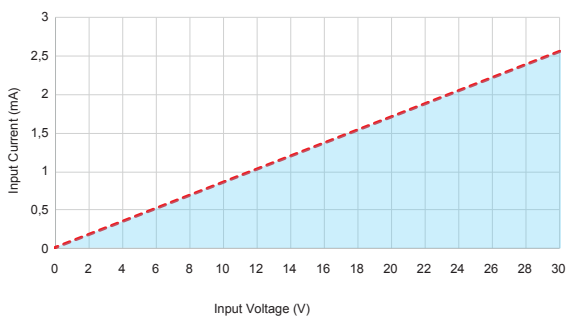

GNR Smart - 84050043N

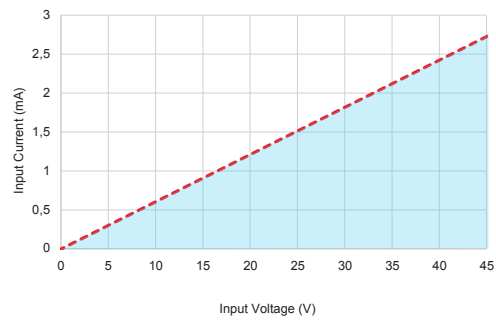

Standard Specifications

84050040N

IEC/EN61000-4-4 (bursts)	1 kv
IEC/EN61000-4-5 (surge)	1 kv
VIBRATION resistance IEC 60068-2-6	2 g, 10/55 Hz
SHOCK resistance IEC 60068-2-27	15 G (11 ms)

84050043N

IEC/EN61000-4-4 (bursts)	1 kv
IEC/EN61000-4-5 (surge)	1 kv
VIBRATION resistance IEC 60068-2-6	2 g, 10/55 Hz
SHOCK resistance IEC 60068-2-27	10 G (11 ms)



Warning:

The product information contained in this catalogue is given purely as information and does not constitute a representation, warranty or any form of contractual commitment. Crouzet and its subsidiaries reserve the right to modify their products without notice. It is imperative that we should be consulted over any particular use or application of our products and it is the responsibility of the buyer to establish, particularly through all the appropriate tests, that the product is suitable for the use or application. Under no circumstances will our warranty apply, nor shall we be held responsible for any application (such as any modification, addition, deletion, use in conjunction with other electrical or electronic components, circuits or assemblies, or any other unsuitable material or substance) which has not been expressly agreed by us prior to the sale of our products.