



Multifunctional Display 573T

Process indicator with two 16 bit analog inputs, touch screen and graphic display

Product Features:

- Operating modes for visualization of input 1, input 2 or combinations of inputs (IN1+IN2, IN2-IN2, IN1xIN2, IN1:IN2)
- Two universal 16 bit analog inputs for -10 ... +10 V / 0 ... 10 V / 0 ... 20 mA / 4 ... 20 mA
- High accuracy reference output 10 V for potentiometers > 1 kOhm
- Bright and high-contrast display with event-dependent color variations
- Emulation of a 7-segment display inclusively icons and units
- Intuitive and easy parameterization by plain text and touchscreen
- 24 V auxiliary output for encoder supply
- Totalization for each input
- Linearization with 24 control points for each input
- Numerous features, e. g. tara, averaging filter, sampling time for each input
- 96 x 48 mm (3.78 x 1.89 inch) norm panel housing and IP65 protection

Order code

6.573T . 01 X . X 0 X . 001

a Relay outputs
0 = 2 relay outputs
2 = without output

b Power supply
3 = 18 ... 30 V DC
E = 18 ... 30 V DC + 115 ... 230 V AC

c Further options
0 = none

d Electrical outputs
0 = none
1 = RS232, 4 switching outputs
2 = RS232, 4 switching outputs, 16 Bit analog output
3 = RS485, 4 switching outputs
4 = RS485, 4 switching outputs, 16 Bit analog output

e Option IO-Link (without IO-Link please omit the last 3 digits from code)
001 = IO-Link

Delivery specification
· Display 573T
· Gasket
· Mounting kit
· Manual German/English

Stock types
6.573T.012.301
6.573T.012.302
6.573T.010.302
6.573T.010.E02

| Version | Description |
|--------------------|---|
| 573T_01a /Jan-17 | First Version |
| 573T_02a /Feb-17 | Second Version |
| 573T_02b /March-17 | minor changes and fixes |
| 573T_3a /Oct-17 | Index 3, expansion of the scale units |
| 573T_4a /April-18 | Extension with IO-Link ➔ in preparation / available on request |
| 573T_5a /June-18 | Extension with Modbus |
| 573T_5b /July-18 | With Modbus and IO-Link description |
| 573T_6a /April-19 | Extension of large display |

Legal notices:

All contents included in this manual are protected by the terms of use and copyrights of Fritz Kübler GmbH.

Any reproduction, modification, usage or publication in other electronic and printed media as well as in the internet requires prior written authorization by Fritz Kübler GmbH.

German is the original version.

Table of Contents

| | | |
|----------|---|-----------|
| 1 | Safety Instructions and Responsibility | 5 |
| 1.1 | General Safety Instructions | 5 |
| 1.2 | Use according to the intended purpose | 5 |
| 1.3 | Installation | 6 |
| 1.4 | Cleaning, Maintenance and Service Notes | 6 |
| 2 | Introduction | 7 |
| 2.1 | Operation mode | 7 |
| 2.2 | Function diagram | 8 |
| 3 | Electrical Connections | 9 |
| 3.1 | DC Power Supply | 9 |
| 3.2 | Auxiliary Voltage Output | 9 |
| 3.3 | Analog Input | 10 |
| 3.4 | Reference Output | 10 |
| 3.5 | Control Inputs | 11 |
| 3.6 | Analog Output (Option) | 11 |
| 3.7 | Serial interface (Option RS232 or RS485) | 12 |
| 3.8 | Control-Output (Option) | 12 |
| 3.9 | AC Power supply (Option) | 13 |
| 3.10 | Relay Output (Option) | 13 |
| 3.11 | IO-Link (Option) | 14 |
| 4 | Display and touch screen | 15 |
| 4.1 | Screen structure for parametrization | 15 |
| 4.2 | Screen structure in operation | 16 |
| 4.3 | Error messages | 17 |
| 5 | Parameter / Overview-Menu Structure | 20 |
| 5.1 | General Menu | 22 |
| 5.2 | IN 1 Properties | 23 |
| 5.3 | IN 1 Linearization | 25 |
| 5.4 | IN 1 Totalization | 26 |
| 5.5 | IN 2 Properties | 27 |
| 5.6 | IN 2 Linearization | 28 |
| 5.7 | IN 2 Totalization | 28 |
| 5.8 | Linkage Properties | 29 |
| 5.9 | IO-Link Properties | 30 |
| 5.10 | Preselection Values | 31 |
| 5.11 | Preselection 1 Menu | 32 |
| 5.12 | Preselection 2 Menu | 36 |
| 5.13 | Preselection 3 Menu | 37 |
| 5.14 | Preselection 4 Menu | 38 |
| 5.15 | Serial Menu | 39 |
| 5.16 | Analog Out Menu | 41 |
| 5.17 | Command Menu | 43 |
| 5.18 | Display Menu | 45 |
| 6 | Appendix | 49 |

| | | |
|-----|---|----|
| 6.1 | 6.1 Data readout via serial interface | 49 |
| 6.2 | Modbus RTU Interface | 50 |
| | 6.2.1 Parameter setting | 50 |
| | 6.2.2 Modbus Communication | 51 |
| | 6.2.3 Diagnostics | 53 |
| 6.3 | IO-Link Modul..... | 53 |
| | 6.3.1 Communications data | 53 |
| | 6.3.2 Features | 53 |
| | 6.3.3 IO-Link interface..... | 54 |
| | 6.3.5 System Commands..... | 65 |
| | 6.3.6 IO-Link Prozessdaten..... | 67 |
| | 6.3.8 Declaration of Conformity IO-Link module..... | 71 |
| 6.4 | Display of scale units..... | 72 |
| 6.6 | Linearization..... | 85 |
| 6.7 | Dimensions..... | 87 |
| 6.8 | Technical specifications | 88 |

1 Safety Instructions and Responsibility

1.1 General Safety Instructions

This operation manual is a significant component of the unit and includes important rules and hints about the installation, function and usage. Non-observance can result in damage and/or impairment of the functions to the unit or the machine or even in injury to persons using the equipment!

Please read the following instructions carefully before operating the device and observe all safety and warning instructions! Keep the manual for later use.

A pertinent qualification of the respective staff is a fundamental requirement in order to use these manual. The unit must be installed, connected and put into operation by a qualified electrician.

Liability exclusion: The manufacturer is not liable for personal injury and/or damage to property and for consequential damage, due to incorrect handling, installation and operation. Further claims, due to errors in the operation manual as well as misinterpretations are excluded from liability.

In addition the manufacturer reserves the right to modify the hardware, software or operation manual at any time and without prior notice. Therefore, there might be minor differences between the unit and the descriptions in operation manual.

The raiser respectively positioner is exclusively responsible for the safety of the system and equipment where the unit will be integrated.

During installation or maintenance all general and also all country- and application-specific safety rules and standards must be observed.

If the device is used in processes, where a failure or faulty operation could damage the system or injure persons, appropriate precautions to avoid such consequences must be taken.

1.2 Use according to the intended purpose

The unit is intended exclusively for use in industrial machines, constructions and systems. Non-conforming usage does not correspond to the provisions and lies within the sole responsibility of the user. The manufacturer is not liable for damages which have arisen through unsuitable and improper use. Please note that device may only be installed in proper form and used in a technically perfect condition (in accordance to the Technical Specifications). The device is not suitable for operation in explosion-proof areas or areas which are excluded by the EN 61010-1 standard.

1.3 Installation

The device is only allowed to be installed and operated within the permissible temperature range. Please ensure an adequate ventilation and avoid all direct contact between the device and hot or aggressive gases and liquids.

Before installation or maintenance, the unit must be disconnected from all voltage-sources. Further it must be ensured that no danger can arise by touching the disconnected voltage-sources.

Devices which are supplied by AC-voltages must be connected exclusively by switches, respectively circuit-breakers with the low voltage network. The switch or circuit-breaker must be placed as near as possible to the device and further indicated as separator.

Incoming as well as outgoing wires and wires for extra low voltages (ELV) must be separated from dangerous electrical cables (SELV circuits) by using a double resp. increased isolation.

All selected wires and isolations must be conform to the provided voltage- and temperature-ranges. Further all country- and application-specific standards, which are relevant for structure, form and quality of the wires, must be ensured. Indications about the permissible wire cross-sections for wiring are described in the Technical Specifications.

Before first start-up it must be ensured that all connections and wires are firmly seated and secured in the screw terminals. All (inclusively unused) terminals must be fastened by turning the relevant screws clockwise up to the stop.

Overvoltages at the connections must be limited to values in accordance to the overvoltage category II.

For placement, wiring, environmental conditions as well as shielding and earthing/grounding of the supply lines the general standards of industrial automation industry and the specific shielding instructions of the manufacturer are valid. Please find all respective hints and rules on www.kuebler.com/download.html --> “[General EMC Rules for Wiring, Screening and Earthing]”.

1.4 Cleaning, Maintenance and Service Notes

To clean the front of the unit please use only a slightly damp (not wet!), soft cloth. For the rear no cleaning is necessary. For an unscheduled, individual cleaning of the rear the maintenance staff or assembler is self-responsible.

During normal operation no maintenance is necessary. In case of unexpected problems, failures or malfunctions the device must be shipped for back to the manufacturer for checking, adjustment and reparation (if necessary). Unauthorized opening and repairing can have negative effects or failures to the protection-measures of the unit.

2 Introduction

This series of display unit is suitable for analog signals (-10 ... 10V or 0/4 ... 20 mA). It is very versatile in use, due to the intuitive handling and the extensive range of functions and options.

2.1 Operation mode

All functions are can be configured in the parameter menu.

The device can be set to one of the following operation modes:

- SINGLE:
single-channel operation of input 1
- DUAL:
two-channel operation of input 1 and 2
- IN 1 + IN 2:
two-channel operation of input 1 and 2 in combination with sum
- IN1 – IN 2:
two-channel operation of input 1 and 2 in combination with difference
- IN 1 x IN 2:
two-channel operation of input 1 and 2 in combination with multiplication
- IN 1 / IN 2:
two-channel operation of input 1 and 2 in combination with division

2.2 Function diagram

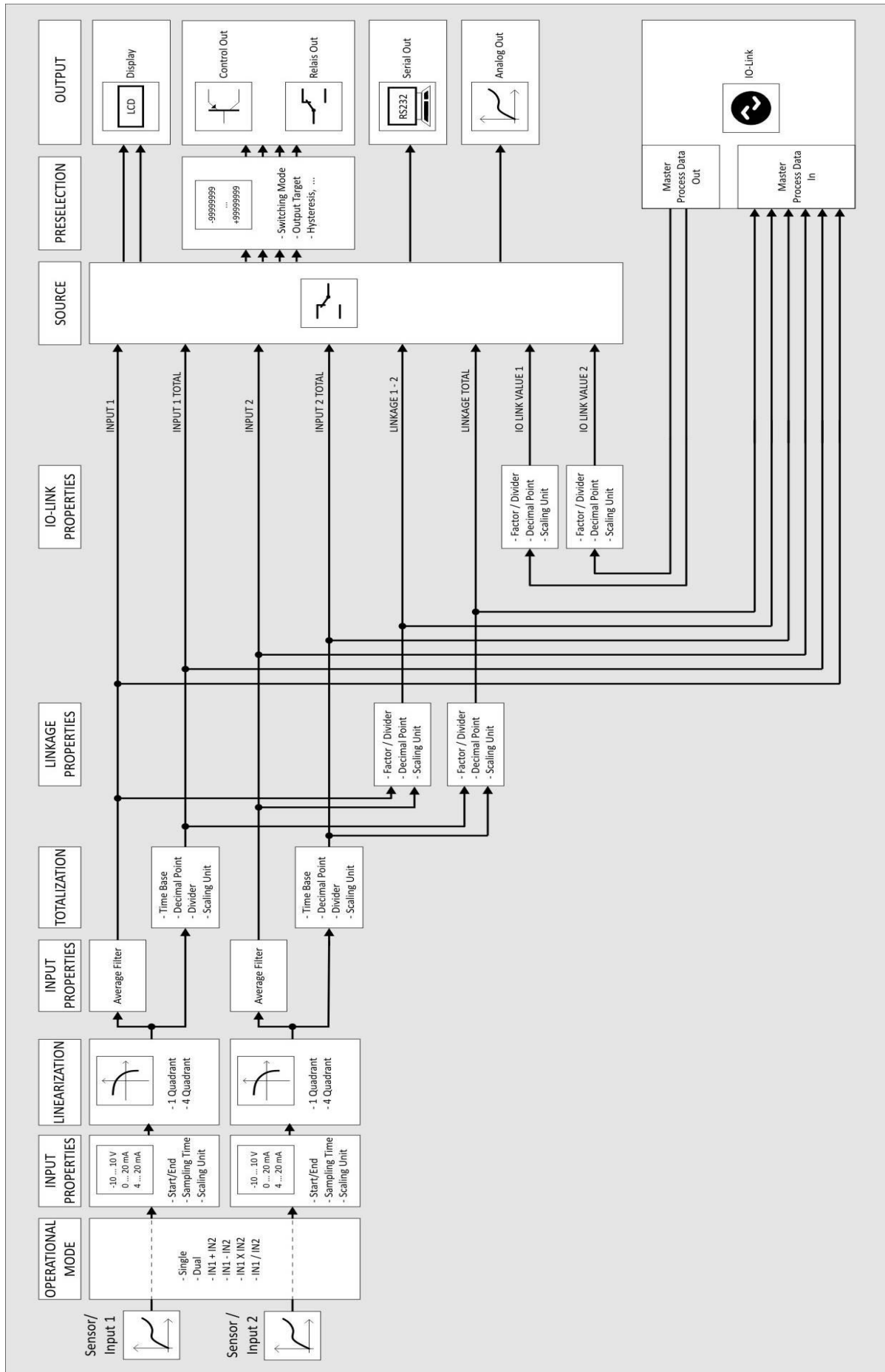

3 Electrical Connections

The terminal screws should be tightened with a slotted screwdriver (blade width 2 mm).

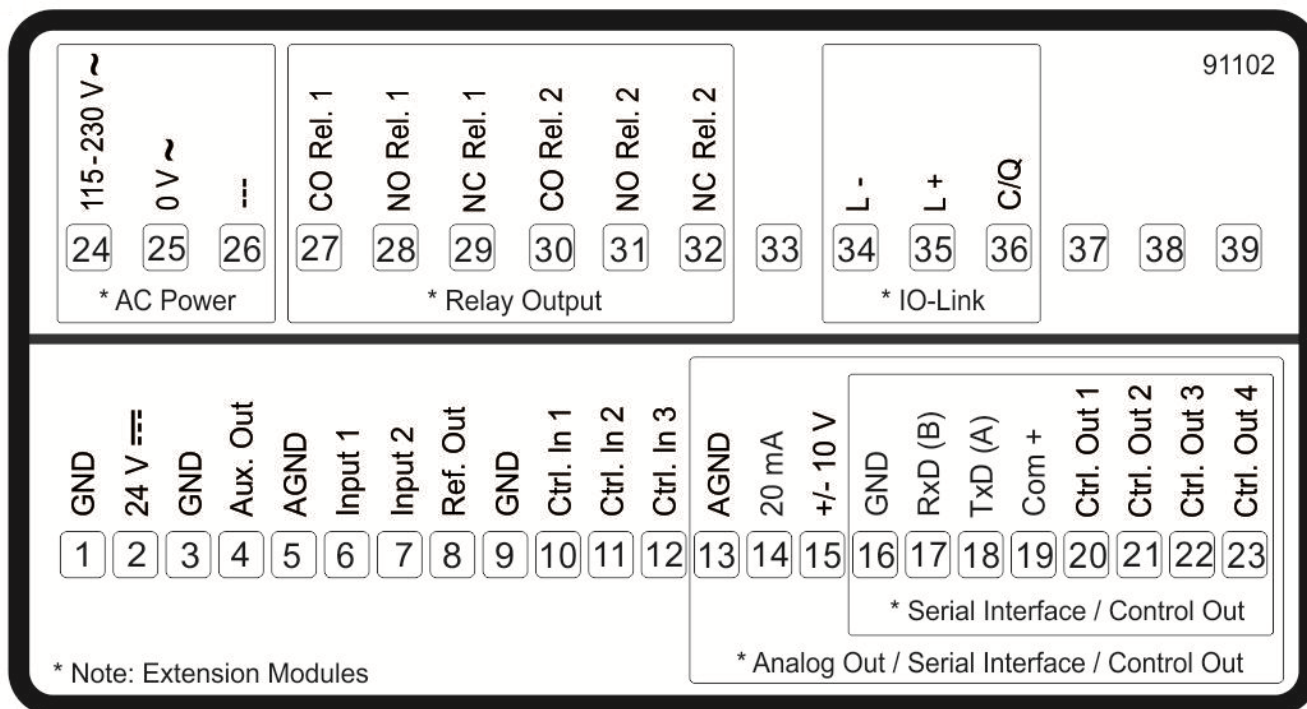

3.1 DC Power Supply

The unit accepts DC supply from 18 to 30 V at the terminals 1 and 2. The power consumption depends on the level of the supply voltage with approx. 100 mA and the additional current required at the auxiliary voltage output.

All GND terminals are internally interconnected.

3.2 Auxiliary Voltage Output

Terminal 3 and 4 provide an auxiliary output for supply of sensors and encoders. The output voltage depends on the power supply.

| DC version | AC version |
|---|--|
| The encoder voltage is approx. 1 V lower than the power supply voltage at terminal 1 and 2 and should be loaded with max. 250 mA. | The encoder voltage is 24 VDC ($\pm 15\%$) and should be loaded with max. 150 mA up to 45 degrees Celsius. At higher temperature the maximum output current is reduced to 80 mA. |

3.3 Analog Input

The reference potential (AGND) for the analog inputs is connected at terminal 5. The unit provides two 16 bit analog inputs at terminal 6 and 7. The characteristics of the analog inputs (voltage input or current input) can be set in the Menu IN 1/IN 2 PROPERTIES.



Important:

Before connecting the sensor the configuration (voltage or current input) must be set!

Wiring of the incremental inputs:

Voltage input

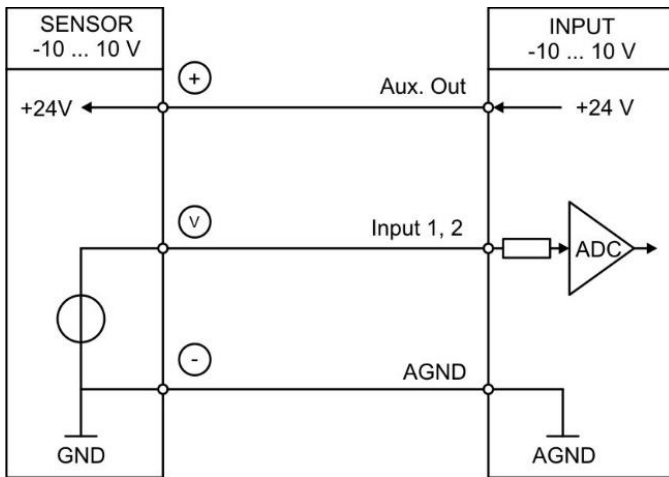

Current input

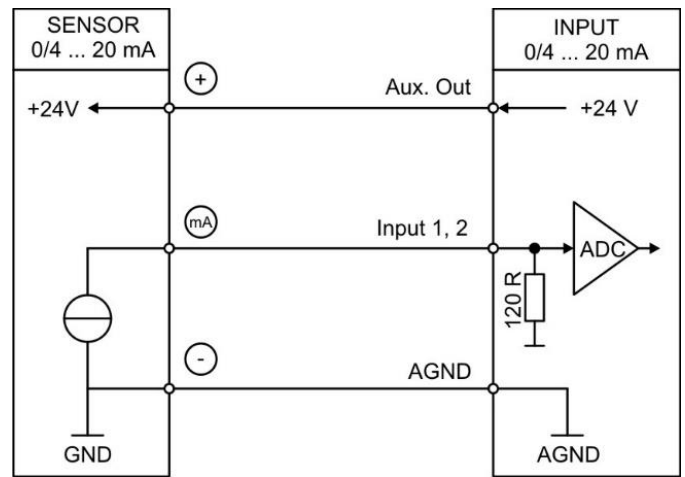

3.4 Reference Output

The unit provides a 10 V reference-output at terminal 8. This output should be loaded with 10 mA maximum. This reference-output can be used for connecting a potentiometer.

Reference output with potentiometer

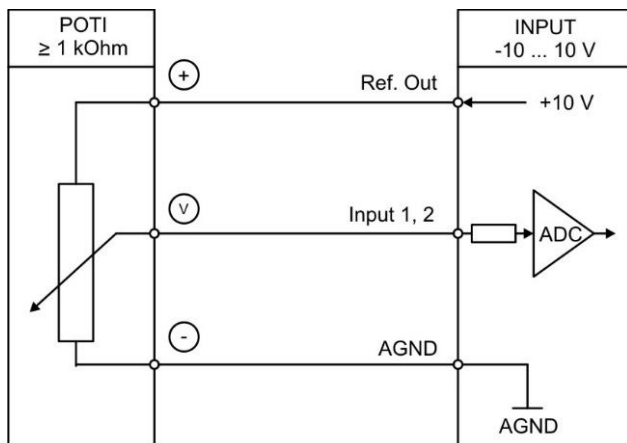

3.5 Control Inputs

The three control inputs at terminal 10, 11 and 12 have HTL PNP characteristics. In the COMMAND MENU the programmable functions for the control inputs can be assigned. Available functions are: reset the display value, display switching, locking the touch screen or release the lock function of the control or relay outputs.

Wiring of the control inputs:

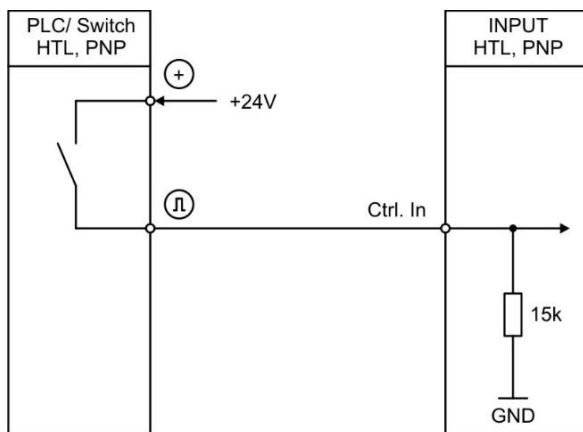

Unconnected control inputs are always “LOW”.

All inputs are designed to receive impulses from an electronic impulse source.

Notice for mechanical switching contacts:

When exceptionally mechanical contacts are used, please connect an external capacitor between GND (-) and the corresponding input (+). A capacity of 10 μ F will reduce the input frequency to 20 Hz and miscounting due to contact bouncing will be eliminated.

3.6 Analog Output (Option)

A 16 bit analog output is available at terminal 13 and 14 / 15.

This output can be configured and scaled in the ANALOG MENU.

The following configuration is possible:

- Voltage output: -10 ... +10 V
- Current output: 0 ... 20 mA
- Current output: 4 ... 20 mA

The analog output is proportional to the reference source and is referenced to potential AGND.

AGND and GND are internally interconnected.



Important:

A parallel operation with voltage and current output at the analog output is not allowed.

3.7 Serial interface (Option RS232 or RS485)

A serial interface (RS232 or RS485) is available at terminal 16, 17 und 18. This interface can be configured in the SERIAL MENU.

The serial interface RS232 or RS485 can be used:

- for easy setup and commissioning of the units
- to modify settings and parameters during operation
- to read out internal states and actual measuring values by PC or PLC

The following drawing shows the connection to a PC by using a standard Sub-D-9 connector:

Connection of the RS232 interface:

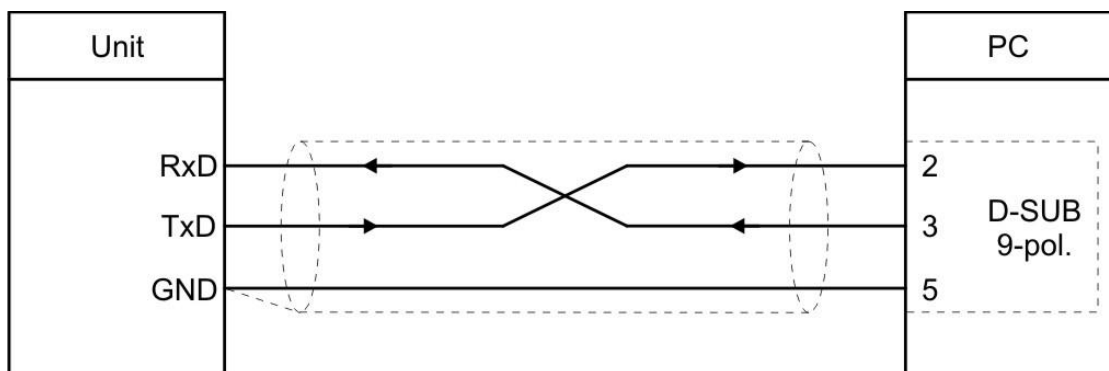

Connection of the RS485 interface:

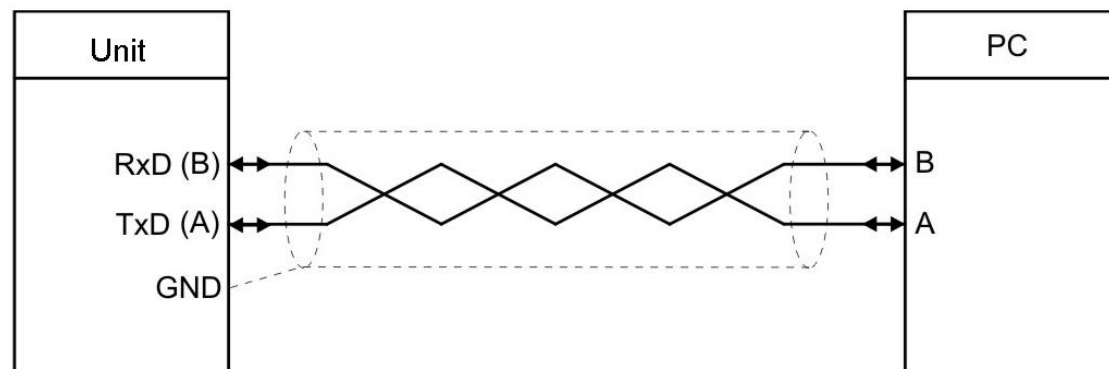

3.8 Control-Output (Option)

Four control outputs are available at terminal 20, 21, 22 and 23.

Switching conditions can be set in the PRESELECTION MENU. The output Ctrl. Out 1 – 4 are fast PNP outputs with a switching capability of 5 – 30 Volt / 200 mA per channel. The switching states is displayed (display with unit and status bar) as C1 ... C4.

The switching voltage of the outputs must be applied to input terminal 19 (COM+).

In case of switching inductive loads it is advisable to use external filtering of the coils. The switching states is displayed (display with unit and status bar) as C1 and C4.

Wiring of the control-outputs:

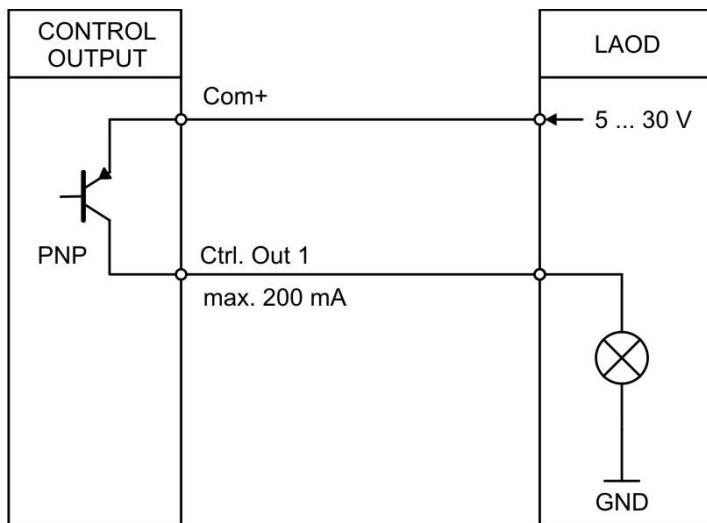

3.9 AC Power supply (Option)

The unit accepts AC supply from 115 to 230 V at the terminals 24 and 25. The power consumption depends on the level of the supply voltage with approx. 3VA and the additional current required at the auxiliary voltage output.

Devices with option AC can also be supplied with a DC voltage between 18 and 30 VDC at terminals 1 and 2.

3.10 Relay Output (Option)

Two relay outputs with potential-free changeover contacts are available at terminal 27, 28, 29 and 30, 31, 32. Switching conditions can be set in the PRESELECTION MENU. The switching states are displayed (display with unit and status bar) as K1 and K2.

AC-switching capacity max. 250 VAC/max. 3 A / max. 750 VA

DC-switching capacity max. 150 VDC /max. 2 A / max. 50 W

Wiring of the relay outputs:

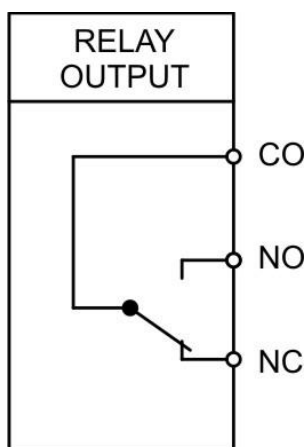

3.11 IO-Link (Option)

An interface for connecting to an IO-Link master is available at terminal 34, 35 and 36. The display device (IO-link device) must always be connected to a separate power supply (AC or DC).

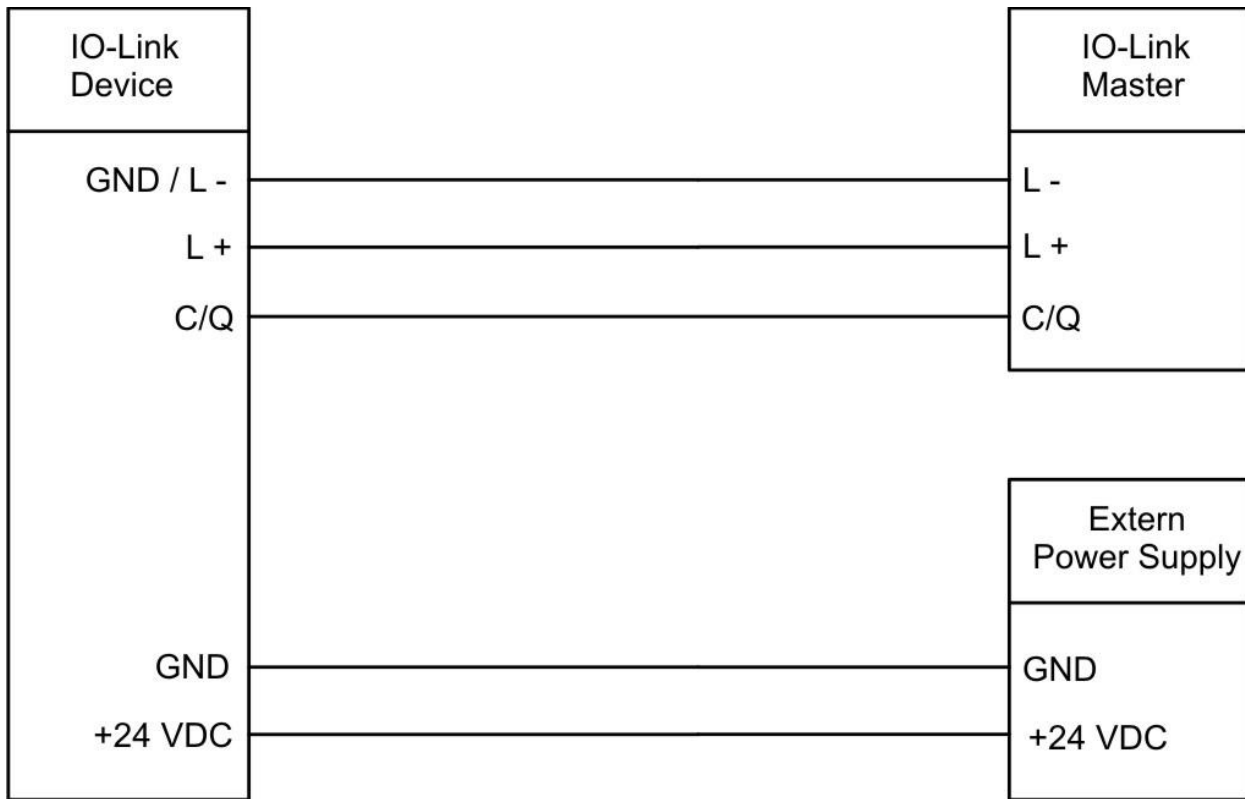

The display device (IO-link device) can be operated in two ways.

- **Display of 2 output process data (8 bytes):**

2 output process data are sent by the IO-Link master cyclically. The two values can be parameterized or scaled in the Menu IO-LINK PROPERTIES.

- **Display for analog sensors and data transmission of 6 input process data (32 Byte):**

6 input process data are sent to the IO-link master cyclically. The following values are submitted:

- Value 1: Result of input 1
- Value 2: Result of input 2
- Value 3: Result of the link from input 1 to input 2
- Value 4: Result of totalization of input 1
- Value 5: Result of totalization of input 2
- Value 6: Result of totalization of the link from input 1 to input 2

These functions/data are defined in the IO-link master.

For more information, see the graph in Chapter 2.2 of the function diagram and in the Chapter "IO-Link-Modul" in this manual.

4 Display and touch screen

4.1 Screen structure for parametrization

The parameter menus and the parameters are described in chapter 5.

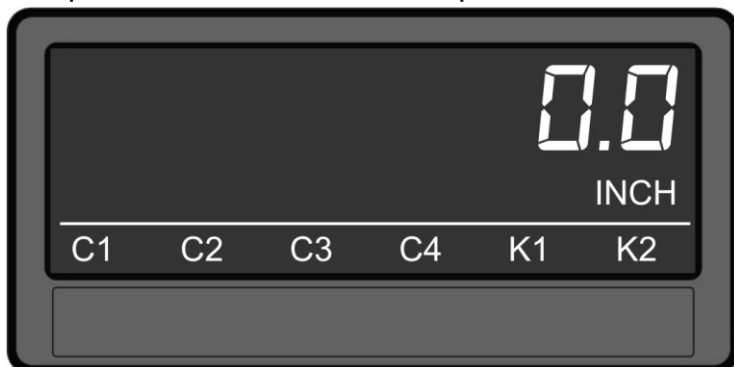

Start setup procedure:

To edit the parameters, press the touchscreen for 3 seconds.



Menu selection:

Select the parameter menu via arrow buttons and confirm with "OK".

The menu selection can be terminated with „C“.



Parameter selection:

Select the parameter via arrow buttons and confirm with „OK“.

The parameter selection can be terminated with „C“.



Parameter editing:

Edit the parameter via arrow button up and down, shift cursor via left and right and save with „OK“.

The parameter editing can be terminated with „C“.

Parameter changes becomes active only after closing the menu selection

4.2 Screen structure in operation

The following screens are available during operation. Depending on the device version and the selected operation mode, not all displays will be shown.

The source (IN1, IN2, ...) for the single channel display and the two channel display are defined in the DISPLAY MENU.



Single line display with unit and status bar

To switch to the next display, press the touch screen.

Control - or Relay status are only shown with Option Analog-, Control-, Relay-Output.



Two-line display

To switch to the next display, press the top of the screen.



Two-line display with units

To switch to the next display, press the top of the screen.



Large Display (4 digits)

To switch to the next display, press the top of the screen.

This is only possible with activated parameter "LARGE DISPLAY".



Display for quick start for enter preselection values (PRESELECT VALUES)

To switch to the next display, press the top of the screen or the “skip” button.

This is only possible with Option Analog-, Control- and / or Relay-Output.



Display with actual / minimum / maximum values of input 1 and input 2

To switch to the next display, type on the touch screen.

4.3 Error messages

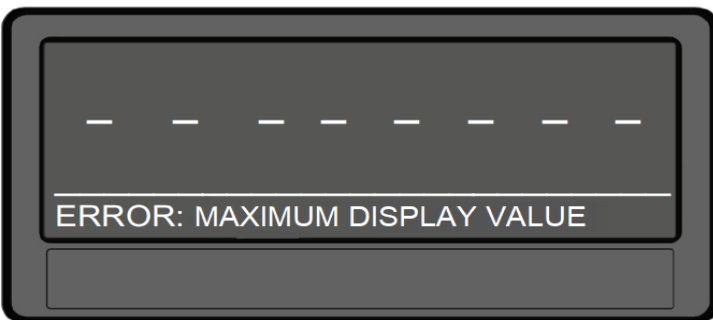

ERROR: MAXIMUM DISPLAY VALUE

The display value of the single line display is greater than +99 999 999

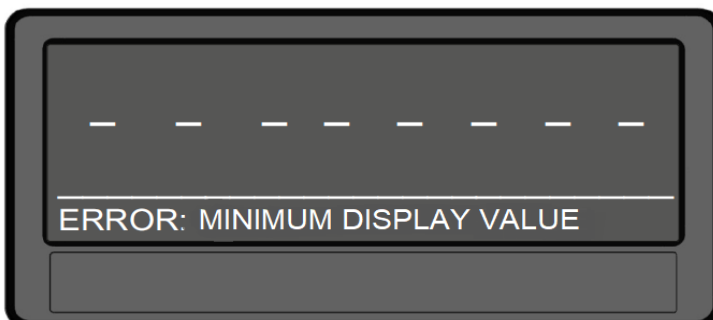

ERROR: MINIMUM DISPLAY VALUE
ERROR: MINIMUM DISPLAY VALUE

The display value of the single line display is less than -99 999 999
The display value of the single line display is less than -99 999 999

Continuation "Error messages":

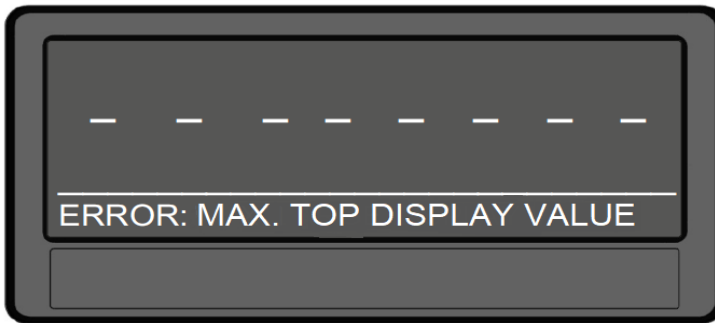

ERROR: MAX. TOP DISPLAY VALUE

Top display value of the two-line display is greater than +99 999 999

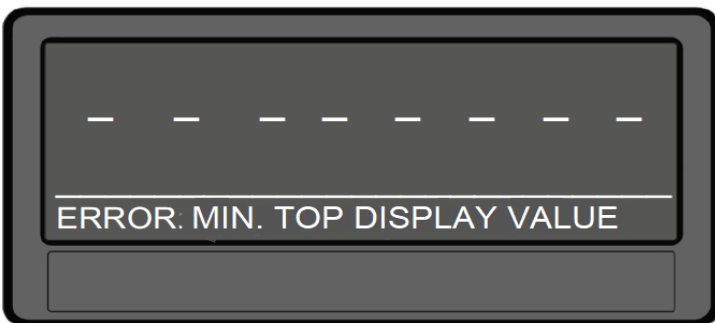

ERROR: MIN. TOP DISPLAY VALUE

Top display value of the two-line display is less than -99 999 999

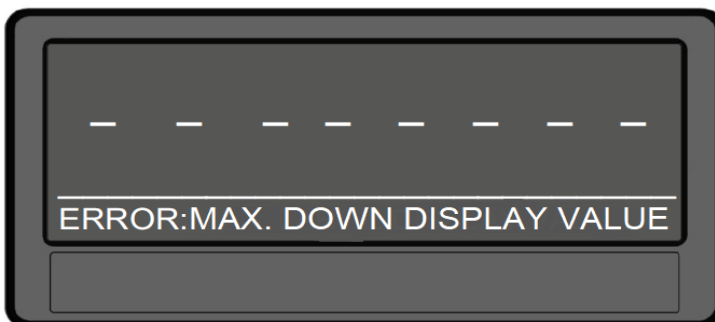

ERROR: MAX. DOWN DISPLAY VALUE

Down display value of the two-line display is greater than +99 999 999

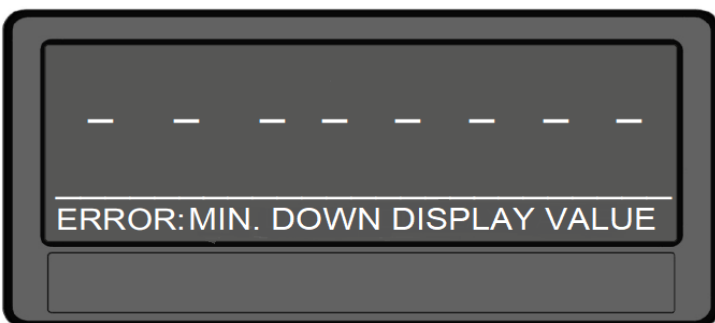

ERROR: MIN. DOWN DISPLAY VALUE

Down display value of the two-line display is less than -99 999 999

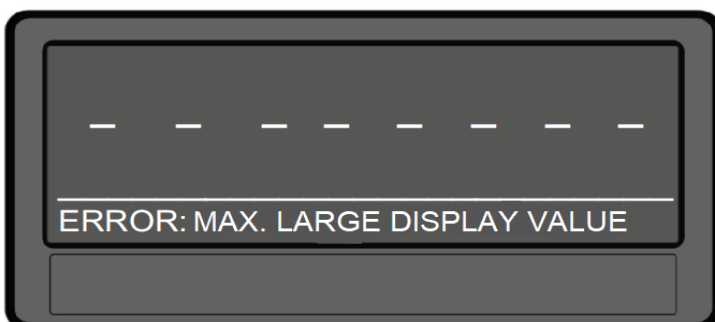

ERROR: MAX. DOWN DISPLAY VALUE

Top display value of the large display is greater than +9999

Continuation "Error messages":

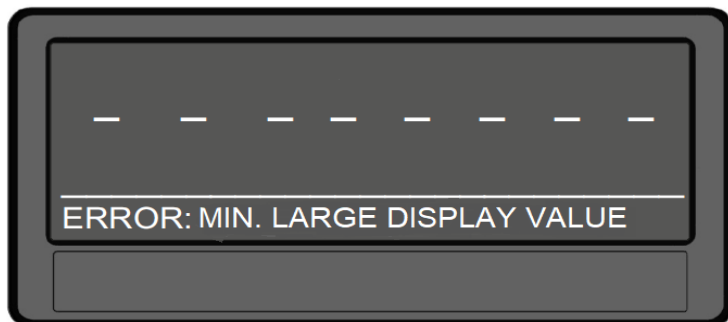

ERROR: MIN: LARGE DISPLAY VALUE

The display value of the large display
is less than 99999



The error messages described are automatically reset as soon as the corresponding display value is within the representable range.

5 Parameter / Overview-Menu Structure

This section provides an overview of the menus and their parameters. The menu names are printed bold and the associated parameters are listed under the menu name. Depending on the device version and the selected operation mode, only the necessary menus / parameters are shown.

| Menu / Parameter | Menu / Parameter |
|---------------------------|---------------------------|
| GENERAL MENU | IN 2 PROPERTIES |
| OPERATIONAL MODE | CONFIGURATION |
| PIN PRESELECTION | START VALUE |
| PIN PARAMETER | END VALUE |
| BACK UP MEMORY | DECIMAL POINT |
| FACTORY SETTINGS | SCALE UNITS |
| IN 1 PROPERTIES | SAMPLING TIME |
| CONFIGURATION | AVERAGE FILTER |
| START VALUE | OFFSET |
| END VALUE | LINEARIZATION |
| DECIMAL POINT | TOTALIZATION |
| SCALE UNITS | IN 2 LINEARIZATION |
| SAMPLING TIME | P1(X) |
| AVERAGE FILTER | P1(Y) |
| OFFSET | P2(X) |
| LINEARIZATION | P2(Y) |
| TOTALIZATION | ... |
| IN 1 LINEARIZATION | ... |
| P1(X) | P23(X) |
| P1(Y) | P23(Y) |
| P2(X) | P24(X) |
| P2(Y) | P24(Y) |
| ... | IN 2 TOTALIZATION |
| ... | TIME BASE |
| P23(X) | DIVIDER |
| P23(Y) | DECIMAL POINT |
| P24(X) | SCALE UNITS |
| P24(Y) | LINKAGE PROPERTIES |
| IN 1 TOTALIZATION | FACTOR |
| TIME BASE | DIVIDER |
| DIVIDER | ADDITIVE VALUE |
| DECIMAL POINT | DECIMAL POINT |
| SCALE UNITS | SCALE UNITS |

| Menu / Parameter |
|--|
| IO LINK PROPERTIES |
| IN1 FACTOR IN1 DIVIDER IN1 ADDITIVE VALUE IN1 DECIMAL POINT IN1 SCALE UNITS IN2 FACTOR IN2 DIVIDER IN2 ADDITIVE VALUE IN2 DECIMAL POINT IN2 SCALE UNITS |
| PRESELECTION VALUES |
| PRESELECTION 1 PRESELECTION 2 PRESELECTION 3 PRESELECTION 4 |
| PRESELECTION 1 MENU |
| SOURCE 1 MODE 1 HYSTERESIS 1 PULSE TIME 1 OUTPUT TARGET 1 OUTPUT POLARITY 1 OUTPUT LOCK 1 START UP DELAY 1 EVENT COLOR 1 |
| PRESELECTION 2 MENU |
| SOURCE 2 MODE 2 HYSTERESIS 2 PULSE TIME 2 OUTPUT TARGET 2 OUTPUT POLARITY 2 OUTPUT LOCK 2 START UP DELAY 2 EVENT COLOR 2 |
| PRESELECTION 3 MENU |
| SOURCE 3 MODE 3 HYSTERESIS 3 PULSE TIME 3 OUTPUT TARGET 3 OUTPUT POLARITY 3 OUTPUT LOCK 3 START UP DELAY 3 EVENT COLOR 3 |

| Menu / Parameter |
|---|
| PRESELECTION 4 MENU |
| SOURCE 4 MODE 4 HYSTERESIS 4 PULSE TIME 4 OUTPUT TARGET 4 OUTPUT POLARITY 4 OUTPUT LOCK 4 START UP DELAY 4 EVENT COLOR 4 |
| SERIAL MENU |
| UNIT NUMBER SERIAL BAUD RATE SERIAL FORMAT SERIAL INIT SERIAL PROTOCOL SERIAL TIMER SERIAL VALUE MODBUS |
| ANALOG OUT MENU |
| ANALOG SOURCE ANALOG FORMAT ANALOG START ANALOG END ANALOG GAIN ANALOG OFFSET |
| COMMAND MENU |
| INPUT 1 ACTION INPUT 1 CONFIG INPUT 2 ACTION INPUT 2 CONFIG INPUT 3 ACTION INPUT 3 CONFIG |
| DISPLAY MENU |
| START DISPLAY SOURCE SINGLE SOURCE DUAL TOP SOURCE DUAL DOWN LARGE DISPLAY SOURCE LARGE COLOR BRIGHTNESS CONTRAST SCREEN SAVER UP-DATE-TIME FONT |

5.1 General Menu

OPERATIONAL MODE

This parameter specifies the selected measuring function.

| | | |
|----------|-------------------|--|
| 0 | SINGLE | Single channel mode, only input 1 |
| 1 | DUAL | Dual channel mode, input 1 and input 2 separated |
| 2 | IN1 + IN 2 | Dual channel mode, sum of input 1 and input 2 |
| 3 | IN1 – IN 2 | Dual channel mode, difference of input 1 and input 2 |
| 4 | IN1 x IN 2 | Dual channel mode, multiplication of input 1 and input 2 |
| 5 | IN1 / IN 2 | Dual channel mode, input 1 divide by input 2 |

PIN PRESELECTION

This parameter defines the PIN-code to lock the quick start of the menu PRESELECTION VALUE for entering the preselection values (master PIN 6079).

This Lock function is only useful in conjunction with active lock function in PIN PARAMETER.

| | | |
|--|-------------|-------------------------------------|
| | 0000 | No lock |
| | ... | |
| | 9999 | Access after entering PIN-Code 9999 |

PIN PARAMETER

This parameter defines the PIN-code for lock function of all parameters (master PIN 6079).

| | | |
|--|-------------|---|
| | 0000 | No lock |
| | ... | |
| | 9999 | Parameterization of the unit after entering PIN-code 9999 |

BACK UP MEMORY

| | | |
|----------|------------|---|
| 0 | NO | No back –up by power failure |
| 1 | YES | Backup by power failure, actual value will be saved, only by totalization |

FACTORY SETTINGS

| | | |
|----------|------------|--|
| 0 | NO | No default values are loaded |
| 1 | YES | Load default values of all parameters (grey marked default values) |

5.2 IN 1 Properties

This menu defines the parameter for input 1.

| CONFIGURATION | | |
|--|---------------------|--------------|
| This parameter defines the configuration of input 1. | | |
| 0 | -10 ... 10 V | -10 ... 10 V |
| 1 | 0 ... 20 MA | 0 ... 20 mA |
| 2 | 4 ... 20 MA | 4 ... 20 mA |

| START VALUE | | |
|---|---------------|----------------------|
| This parameter defines the display value of an input signal of 0V, 0mA or 4mA. Signal values between START VALUE and END VALUE behave proportional. | | |
| | -99999 | Smallest start value |
| | 0 | Default value |
| | 99999 | Highest start value |

| END VALUE | | |
|--|---------------|--------------------|
| This parameter defines the display value of an input signal +10V or 20mA. Signal values between START VALUE and END VALUE behave proportional. | | |
| | -99999 | Smallest end value |
| | 10000 | Default value |
| | 99999 | Highest end value |

| DECIMAL POINT | | |
|---|------------------|---|
| This value defines the position of the decimal point. | | |
| 0 | NO | No decimal point |
| 1 | 0000000.0 | Decimal point at the specified position |
| 2 | 000000.00 | Decimal point at the specified position |
| 3 | 00000.000 | Decimal point at the specified position |
| 4 | 0000.0000 | Decimal point at the specified position |
| 5 | 000.00000 | Decimal point at the specified position |
| 6 | 00.000000 | Decimal point at the specified position |
| 7 | 0.0000000 | Decimal point at the specified position |

| SCALE UNITS | | |
|---|--|--|
| This parameter defines the required engineering unit. This parameter does not affect the calculation of the display value. The number of decimal places must be defined with the parameter DECIMAL POINT. A list of available units can be found in Chapter 6.2 Appendix: Display of scale units. | | |

Continuation “IN 1 Properties”:

SAMPLING TIME (S)

The configured value corresponds to the sampling interval. This time interval in seconds defines the time between the single samples of the analog signals. This parameter directly affects the response time of the unit.

| | | |
|--|---------------|------------------------|
| | 0.001 | Shortest sampling time |
| | 0.01 | Default value |
| | 60.000 | Longest sampling time |

AVERAGE FILTER

Selectable average filter function to avoid measuring fluctuations.

| | | |
|--|----------|---------------------------------------|
| | 0 | No average value will be created |
| | 1 | 2 numbers of floating average cycles |
| | 2 | 4 numbers of floating average cycles |
| | 3 | 8 numbers of floating average cycles |
| | 4 | 16 numbers of floating average cycles |

OFFSET

This parameter defines the zero offset / tara of the input.
This parameter does not affect the TOTALIZATION function.

| | | |
|--|----------------|-----------------|
| | -99.999 | Smallest offset |
| | 0 | Default value |
| | +99.999 | Highest offset |

LINEARIZATION

This parameter defines the linearization function.
The linearization points are defined in Menu IN 1 / IN 2 LINEARIZATION.
See appendix.

| | | | |
|--|----------|-------------------|----------------------------------|
| | 0 | OFF | No linearization |
| | 1 | 1 QUADRANT | Linearization in the 1. quadrant |
| | 2 | 4 QUADRANT | Linearization in all 4 quadrants |

TOTALIZATION

This parameter activates the totalization function. The settings will be done in Menu IN 1 / IN 2 TOTALIZATION.
The totalization depends on the operation mode. See chart in chapter IN 1 Totalization.

| | | | |
|--|----------|------------|------------------------|
| | 0 | OFF | No totalization |
| | 1 | ON | Totalization is active |

5.3 IN 1 Linearization

The linearization points of input 1 are defined in this menu.

This menu is shown only, if the linearization is selected in 1 PROPERTIES.

Linearization description and examples are shown in the appendix.

P1(X) ... P24(X)

X-coordinate of the linearization point.

This value representing the display value which the unit show in the display without linearization.

| | | |
|--|------------------|-----------------------|
| | -99999999 | Smallest X-coordinate |
| | 0 | Default value |
| | +99999999 | Largest X-coordinate |

P1(Y) ... P24(Y)

Y-coordinate of the linearization point

This is the display value, which the unit should show in the display with linearization.

E.g. P2(X) is replaced by P2(Y).

| | | |
|--|------------------|-----------------------|
| | -99999999 | Smallest Y-coordinate |
| | 0 | Default value |
| | +99999999 | Largest Y-coordinate |

5.4 IN 1 Totalization

The totalization function is defined in this menu. This menu will only be showed, if the totalization is active in Menu IN 1 PROPERTIES. The totalizator depends on the operation mode. See in the following list.

| Operation mode | Totalization | | |
|----------------|---------------|---------------|-------------------|
| | INPUT 1 TOTAL | INPUT 2 TOTAL | LINKAGE TOTAL |
| SINGLE | active | → 0 | → 0 |
| DUAL | active | active | → 0 |
| IN1 + IN 2 | active | active | Total 1 + Total 2 |
| IN1 – IN 2 | active | active | Total 1 - Total 2 |
| IN1 x IN 2 | active | active | → 0 |
| IN1 / IN 2 | active | active | → 0 |

TIME BASE

This parameter defines the time base of the totalization. It defines the time interval between the recordings of data.

| | | |
|----------|----------------|---|
| 0 | SECONDS | The current value is added to INPUT 1 TOTAL every second |
| 1 | MINUTES | The current value is added to INPUT 1 TOTAL every minute |
| 2 | HOURS | The current value is added to INPUT 1 TOTAL every hour |
| 3 | COMMAND | The current value is added to INPUT 1 TOTAL, when using the command (ADD TO TOTAL 1) for the operation function at the control input (see Command Menu) |

DIVIDER

This parameter defines the divisor for the totalization.

| | | |
|----------|-------------|---|
| 0 | 1 | No division |
| 1 | 10 | The result of the totalization is divided by 10 |
| 2 | 100 | The result of the totalization is divided by 100 |
| 3 | 1000 | The result of the totalization is divided by 1000 |

DECIMAL POINT

This value defines the position of the decimal point.

| | | |
|----------|------------------|---|
| 0 | NO | No decimal point |
| 1 | 000000.0 | Decimal point at the specified position |
| 2 | 000000.00 | Decimal point at the specified position |
| 3 | 00000.000 | Decimal point at the specified position |
| 4 | 0000.0000 | Decimal point at the specified position |
| 5 | 000.00000 | Decimal point at the specified position |
| 6 | 00.000000 | Decimal point at the specified position |
| 7 | 0.0000000 | Decimal point at the specified position |

SCALE UNITS

This parameter defines the required engineering unit. This parameter does not affect the calculation of the display value. The number of decimal places must be defined with the parameter DECIMAL POINT. A list of available units can be found in Chapter 6.2 Appendix: Display of scale units.

5.5 IN 2 Properties

This menu defines the parameter for input 2.

CONFIGURATION

Configuration of input 2, see IN 1 Properties

START VALUE

Display value of input 2 at 0 V or 0/4 mA, see IN 1 Properties

END VALUE

Display value of input 2 at +10 V or 20 mA, see IN 1 Properties

DECIMAL POINT

Position of the decimal point, see IN 1 Properties

SCALE UNITS

The displayed units, see IN 1 Properties

SAMPLING TIME (S)

Sampling interval of input 2, see IN 1 Properties

AVERAGE FILTER

Selectable averages filter function, see IN 1 Properties.

OFFSET

Zero offset / tara, see IN 1 Properties

LINEARISATION

Linearization function, see IN 1 Properties.

TOTALIZATION

Totalization function, see IN 1 Properties.

5.6 IN 2 Linearization

The linearization points of input 2 are defined in this menu.

P1(X) ... P24(X)

X-coordinate of the linearization point, see IN 1 Linearization.

P1(Y) ... P24(Y)

Y-coordinate of the linearization point, see IN 1 Linearization.

5.7 IN 2 Totalization

The totalization of input 2 function is defined in this menu.

TIME BASE

The time base of the totalization, see IN 1 Totalization

DIVIDER

The divisor for the totalization, see IN 1 Totalization.

DECIMAL POINT

Position of the decimal point, see IN 1 Totalization

SCALE UNITS

The displayed units, see IN 1 P Totalization

5.8 Linkage Properties

In this menu the parameters for the linked operation mode are defined.

This menu is shown only, if in GENERAL MENU an operation mode (e.g. IN1 – IN2) with link was selected.

The parameters in Menu IN 1 PROPERTIES and IN 2 PROPERTIES have to be set, before using a linked operation mode.

The result of the link can be scaled with the following parameters.

| FACTOR | | |
|--|------------------|-------------------|
| This parameter defines the factor, the result of the link will be charged. | | |
| | -99999999 | Smallest value |
| | 1 | Default value |
| | 99999999 | Highest end value |

| DIVIDER | | |
|---|------------------|--------------------|
| This parameter defines the divider, the result of the link will be charged. | | |
| | -99999999 | Smallest end value |
| | 1 | Default value |
| | 99999999 | Highest end value |

| ADDITIVE VALUE | | |
|---|------------------|--------------------|
| This parameter defines the additive constant, the result of the link will be charged. | | |
| | -99999999 | Smallest end value |
| | 0 | Default value |
| | 99999999 | Highest end value |

| DECIMAL POINT | | |
|---|------------------|---|
| This value defines the position of the decimal point. | | |
| 0 | NO | No decimal point |
| 1 | 000000.0 | Decimal point at the specified position |
| 2 | 000000.00 | Decimal point at the specified position |
| 3 | 00000.000 | Decimal point at the specified position |
| 4 | 0000.0000 | Decimal point at the specified position |
| 5 | 000.00000 | Decimal point at the specified position |
| 6 | 00.000000 | Decimal point at the specified position |
| 7 | 0.0000000 | Decimal point at the specified position |

| SCALE UNITS | | |
|---|--|--|
| This parameter defines the required engineering unit. This parameter does not affect the calculation of the display value. The number of decimal places must be defined with the parameter DECIMAL POINT. A list of available units can be found in Chapter 6.2 Appendix: Display of scale units. | | |

5.9 IO-Link Properties

This menu defines the parameters for the display of the two output process data.

This menu is only displayed if the device is equipped with the option (IO-Link Modul).

| | | |
|---|------------------|-------------------|
| IN1 FACTOR (Multiplication factor) This parameter defines the factor the received value is multiplied with. | | |
| | -99999999 | Smallest value |
| | 1 | Default value |
| | 99999999 | Highest end value |

| | | |
|---|------------------|-------------------|
| IN1 DIVIDER (Dividing factor) This parameter defines the factor the received value is divided by. | | |
| | -99999999 | Smallest value |
| | 1 | Default value |
| | 99999999 | Highest end value |

| | | |
|---|------------------|-------------------|
| IN1 ADDITIVE VALUE (Additive value) This parameter defines the factor the received value is added with. | | |
| | -99999999 | Smallest value |
| | 0 | Default value |
| | 99999999 | Highest end value |

| | | |
|--|--------------------|---|
| IN1 DECIMAL POINT (decimal point) This setting determines the position of the decimal point. | | |
| | 0 NO | No decimal point |
| | 1 000000.0 | Decimal point at the specified location |
| | 2 000000.00 | Decimal point at the specified location |
| | 3 00000.000 | Decimal point at the specified location |
| | 4 0000.0000 | Decimal point at the specified location |
| | 5 000.00000 | Decimal point at the specified location |
| | 6 00.000000 | Decimal point at the specified location |
| | 7 0.0000000 | Decimal point at the specified location |

| | | |
|---|--|--|
| IN1 SCALE UNITS This parameter defines the required engineering unit. This parameter does not affect the calculation of the display value. The number of decimal places must be defined with the parameter DECIMAL POINT. A list of available units can be found in Chapter 6.2 Appendix: Display of scale units. | | |
|---|--|--|

| |
|--|
| IN2 FACTOR (multiplication factor for value 2, see IN 1 factor) |
|--|

| |
|---|
| IN2 DIVIDER (dividing factor for value 2, see IN1 Divider) |
|---|

| |
|--|
| IN2 ADDITIVE VALUE (additive value for value 2, see IN1 ADDITIVE VALUE) |
|--|

| |
|---|
| IN2 DECIMAL POINT (decimal point for value 2, see IN1 DECIMAL POINT) |
|---|

| |
|---|
| IN2 SCALE UNITS (scale units for value 2, see IN1 SCALING UNITS) |
|---|

5.10 Preselection Values

This menu is used to set the preselection values or the switching points.

The preselection values / switching points are always referred to the display value.

This menu is only available for devices with option Control-, Analog- or Relay-Output.

| PRESELECTION 1 | | |
|----------------------------------|------------------|----------------|
| Preselection / switching point 1 | | |
| | -99999999 | Smallest value |
| | 1000 | Default value |
| | +99999999 | Highest value |

| PRESELECTION 2 | | |
|----------------------------------|------------------|----------------|
| Preselection / switching point 2 | | |
| | -99999999 | Smallest value |
| | 2000 | Default value |
| | +99999999 | Highest value |

| PRESELECTION 3 | | |
|----------------------------------|------------------|----------------|
| Preselection / switching point 3 | | |
| | -99999999 | Smallest value |
| | 3000 | Default value |
| | +99999999 | Highest value |

| PRESELECTION 4 | | |
|----------------------------------|------------------|----------------|
| Preselection / switching point 4 | | |
| | -99999999 | Smallest value |
| | 4000 | Default value |
| | +99999999 | Highest value |

5.11 Preselection 1 Menu

Switching conditions for preselection 1. Output/ relay/ display switches under the following conditions.

This function is only available for devices with option Control-, Analog- or Relay-Output.

| SOURCE 1 | | |
|--|------------------------|---|
| This parameter defines the reference source for PRESELECTION 1 | | |
| 0 | INPUT 1 | the reference source is input 1 |
| 1 | INPUT 2 | the reference source is input 2 |
| 2 | LINKAGE 1 – 2 | the reference source is the result of the linking of input1 and input 2 |
| 3 | INPUT 1 TOTAL | the reference source is input 1 with totalization |
| 4 | INPUT 2 TOTAL | the reference source is input 2 with totalization |
| 5 | LINKAGE TOTAL | the reference source is the result of the linking of input1 and input 2 with totalization |
| 6 | IO LINK VALUE 1 | the reference source is the process data out value 1 sent by the IO-Link master |
| 7 | IO LINK VALUE 2 | the reference source is the process data out value 2 sent by the IO-Link master |
| 8 | MINIMUM VALUE 1 | minimum value, the reference source is input 1 |
| 9 | MAXIMUM VALUE 1 | maximum value, the reference source is input 1 |
| 10 | MINIMUM VALUE 2 | minimum value, the reference source is input 2 |
| 11 | MAXIMUM VALUE 2 | maximum value, the reference source is input 2 |

The totalization depends on the operation mode. See chart in chapter IN 1 Totalization.

Continuation „Preselection 1 Menu“:

| MODE 1 | | |
|--|----------------------------|--|
| Switching conditions for preselection 1. Output/ relay/ display switches under the following conditions: | | |
| 0 | RESULT >= PRES | <p>Absolute value of the display value is greater or equal absolute value of PRESELECTION 1</p> <p>With HYSTERESIS 1 not equal 0 the following switching condition is applied: Display value >= PRESELECTION 1 → ON, Display value < PRESELECTION 1 – HYSTERESIS 1 → OFF</p> |
| 1 | RESULT <= PRES | <p>Absolute value of the display value is less or equal absolute value of PRESELECTION 1 (start-up suppression (START UP DELAY) is advisable)</p> <p>With HYSTERESIS 1 not equal 0 the following switching condition is applied: Display value <= PRESELECTION 1 → ON, Display value > PRESELECTION 1 + HYSTERESIS 1 → OFF</p> |
| 2 | RESULT = PRES | <p>Absolute value of the display value is equal absolute value of PRESELECTION 1 A range (Preselection +/- ½ Hysteresis) can be defined and monitored in conjunction with the hysteresis.</p> <p>With HYSTERESIS 1 not equal 0 the following switching condition is applied: Display value > PRESELECTION 1 + ½ HYSTERESIS 1 → OFF, Display value < PRESELECTION 1 - ½ HYSTERESIS 1 → OFF</p> |
| 3 | RESULT>=PRES | <p>Display value is greater or equal PRESELECTION 1, e.g. overspeed</p> <p>With HYSTERESIS 1 not equal 0 the following switching condition is applied: Display value >= PRESELECTION 1 → ON, Display value < PRESELECTION 1 – HYSTERESIS 1 → OFF</p> |
| 4 | RESULT<=PRES | <p>Display value is less or equal PRESELECTION 1, e.g. underspeed (start-up suppression (START UP DELAY) is advisable)</p> <p>With HYSTERESIS 1 not equal 0 the following switching condition is applied: Display value <= PRESELECTION 1 → ON, Display value > PRESELECTION 1 + HYSTERESIS 1 → OFF</p> |
| 5 | RESULT=PRES | <p>Display value is equal PRESELECTION 1. A range (Preselection +/- ½ Hysteresis) can be defined and monitored in conjunction with the hysteresis.</p> <p>With HYSTERESIS 1 not equal 0 the following switching condition is applied: Display value > PRESELECTION 1 + ½ HYSTERESIS 1 → OFF, Display value < PRESELECTION 1 - ½ HYSTERESIS 1 → OFF</p> |
| 6 | RES>=PRES-TRAIL | <p>Trailing PRESELECTION 1: Display value is greater or equal PRESELECTION 2 – PRESELECTION 1, PRESELECTION 1 is the trailing preselection from PRESELECTION 2.</p> |

Continuation „Preselection 1 Menu“:

| | | |
|--|--------------|-------------------------------|
| HYSTERESIS 1 | | |
| This parameter defines the switching hysteresis of the switch-off point for preselection 1 | | |
| | 0 | No switching hysteresis |
| | ... | |
| | 99999 | Switching hysteresis of 99999 |

| | | |
|--|---------------|---------------------------------|
| PULSE TIME 1 (S) | | |
| Duration of output pulse for the switching condition of preselection 1 | | |
| | 0.000 | No output pulse (static signal) |
| | ... | |
| | 60.000 | Pulse duration of 60 seconds |

| | | |
|--|---------------------|---|
| OUTPUT TARGET 1 | | |
| Assignment of an output or relay for the switching condition of preselection 1. If more than one switching condition is assigned to one output / relay, the output is set when at least one switching condition is true | | |
| | 0 NO | No assignment |
| | 1 CTRL OUT 1 | Switching condition assigned to "Ctrl. Out 1" |
| | 2 CTRL OUT 2 | Switching condition assigned to "Ctrl. Out 2" |
| | 3 CTRL OUT 3 | Switching condition assigned to "Ctrl. Out 3" |
| | 4 CTRL OUT 4 | Switching condition assigned to "Ctrl. Out 4" |
| | 5 RELAY 1 | Switching condition assigned to "Rel. 1" |
| | 6 RELAY 2 | Switching condition assigned to "Rel. 2" |

| | | |
|--|----------------------|---|
| OUTPUT POLARITY 1 | | |
| Polarity for the switching condition of preselection 1 | | |
| | 0 ACTIVE HIGH | Switching condition is true → Active „HIGH“ |
| | 1 ACTIVE LOW | Switching condition is true → Active „LOW“ |

| | | |
|---|--------------|--|
| OUTPUT LOCK 1 | | |
| Latch for the switching condition of preselection 1 | | |
| | 0 NO | No latch for preselection |
| | 1 YES | Latch for preselection (command LOCK RELEASE will clear latch) |

Continuation „Preselection 1 Menu“:

| | | |
|---|---------------|---------------------------------|
| START UP DELAY 1 (S) | | |
| Start-up suppression for the switching condition of preselection 1. Time to start the monitoring function. This adjustment is only valid for the switching condition $ RESULT \leq PRES $ or $RESULT \leq PRES$ (Start Up Delay 3 and 4 have an automatic start up suppression). | | |
| | 0.000 | No start-up suppression |
| | ... | |
| | 60.000 | Start-up suppression in seconds |

| | | | |
|--|----------|-------------------------|------------------------|
| EVENT COLOR 1 | | | |
| Event-depending change of the display color for the switching condition of preselection 1. EVENT COLOR 1 has the lowest priority. EVENT COLOR 2 ... 4 are allowed to overwrite this color change. | | | |
| | 0 | NO CHANGE | No color change. |
| | 1 | CHANGE TO RED | Color change to red |
| | 2 | CHANGE TO GREEN | Color change to green |
| | 3 | CHANGE TO YELLOW | Color change to yellow |

5.12 Preselection 2 Menu

SOURCE 2

The reference source for PRESELECTION 2, see PRESELECTION 1 MENU

MODE 2

Switching conditions for preselection 2, see PRESELECTION 1 MENU (expect trailing preselection)

| | | | |
|---|-----------------|--|--|
| | | | See chapter PRESELECTION 1 MENU |
| 6 | RES>=PRES-TRAIL | | Trailing preselection 2: Display value is greater or equal to PRESELECTION 1 – PRESELECTION 2 PRESELECTION 2 is the trailing preselection from PRESELECTION 1. |

HYSTERESIS 2

This parameter defines the switching hysteresis of the switch-off point for preselection 2.

See chapter PRESELECTION 1 MENU

PULSE TIME 2 (S)

Duration of output pulse for the switching condition of preselection 2.

See chapter PRESELECTION 1 MENU.

OUTPUT TARGET 2

Assignment of an output or relay for the switching condition of preselection 2.

See chapter PRESELECTION 1 MENU (expect default value).

| | | | |
|---|------------|--|---|
| | | | see PRESELECTION 1 MENU |
| 2 | CTRL OUT 2 | | Assignment of switching conditions at Ctrl. Out 2 |

OUTPUT POLARITY 2

Polarity for the switching condition of preselection 2.

See chapter PRESELECTION 1 MENU.

OUTPUT LOCK 2

Latch for the switching condition of preselection 2.

See chapter PRESELECTION 1 MENU.

START UP DELAY 2 (S)

Start-up suppression for the switching condition of preselection 2.

See chapter PRESELECTION 1 MENU.

(Start Up Delay 3 and 4 have an automatic start up suppression).

EVENT COLOR 2

Event-depending change of the display color for the switching condition of preselection 2.

See chapter PRESELECTION 1 MENU.

5.13 Preselection 3 Menu

SOURCE 3

The reference source for PRESELECTION 3, see PRESELECTION 1 MENU

MODE 3

Switching conditions for preselection 3, see PRESELECTION 1 MENU (expect trailing preselection)

| | | | |
|--|---|-----------------|--|
| | | | See chapter PRESELECTION 1 MENU |
| | 6 | RES>=PRES-TRAIL | Trailing preselection 3: Display value is greater or equal to PRESELECTION 4 – PRESELECTION 3 PRESELECTION 3 is the trailing preselection from PRESELECTION 4. |

HYSTERESIS 3

This parameter defines the switching hysteresis of the switch-off point for preselection 3.
See chapter PRESELECTION 1 MENU.

PULSE TIME 3 (S)

Duration of output pulse for the switching condition of preselection 3.
See chapter PRESELECTION 1 MENU (except default value).

OUTPUT TARGET 3

Assignment of an output or relay for the switching condition of preselection 3.
See chapter PRESELECTION 1 MENU.

| | | | |
|--|---|------------|---|
| | | | see PRESELECTION 1 MENU |
| | 3 | CTRL OUT 3 | Assignment of switching conditions at Ctrl. Out 3 |

OUTPUT POLARITY 3

Polarity for the switching condition of preselection 3.
See chapter PRESELECTION 1 MENU.

OUTPUT LOCK 3

Latch for the switching condition of preselection 3.
See chapter PRESELECTION 1 MENU.

START UP DELAY 3

Start-up suppression for the switching condition of preselection 3.
This adjustment is only valid for the switching condition $|RESULT| \leq |PRES|$ or $RESULT \leq$
(Start Up Delay 1 and 2 have a time-dependent start up suppression).

| | | | |
|--|---|------|---|
| | 0 | OFF | No start-up suppression |
| | 1 | AUTO | Automatic start up suppression, until the preselection value / switching point is exceeded for the first time. |

EVENT COLOR 3

Event-dependending change of the display color for the switching condition of preselection 3.
See chapter PRESELECTION 1 MENU.

5.14 Preselection 4 Menu

SOURCE 4

The reference source for PRESELECTION 4, see PRESELECTION 1 MENU

MODE 4

Switching conditions for preselection 4, see PRESELECTION 1 MENU (expect trailing preselection)

| | | | |
|--|---|-----------------|--|
| | | | See chapter PRESELECTION 1 MENU |
| | 6 | RES>=PRES-TRAIL | Trailing preselection 4: Display value is greater or equal to PRESELECTION 3 – PRESELECTION 4 PRESELECTION 4 is the trailing preselection from PRESELECTION 3. |

HYSTERESIS 4

This parameter defines the switching hysteresis of the switch-off point for preselection 4.
See chapter PRESELECTION 1 MENU.

PULSE TIME 4 (S)

Duration of output pulse for the switching condition of preselection 3.
See chapter PRESELECTION 1 MENU.

OUTPUT TARGET 4

Assignment of an output or relay for the switching condition of preselection 4.
See chapter PRESELECTION 1 MENU (except default value).

| | | | |
|--|---|------------|---|
| | | | see PRESELECTION 1 MENU |
| | 4 | CTRL OUT 4 | Assignment of switching conditions at Ctrl. Out 4 |

OUTPUT POLARITY 4

Polarity for the switching condition of preselection 4.
See chapter PRESELECTION 1 MENU.

OUTPUT LOCK 4

Latch for the switching condition of preselection 4.
See chapter PRESELECTION 1 MENU.

START UP DELAY 4

Start-up suppression for the switching condition of preselection 4, see PRESELECTION 3 MENU.
(Start Up Delay 1 and 2 have a time-dependent start up suppression).

| | | | |
|--|---|------|--|
| | 0 | OFF | Automatic start up suppression, |
| | 1 | AUTO | until the preselection value / switching point is exceeded for the first time. |

EVENT COLOR 4

Event-depending change of the display color for the switching condition of preselection 4.
See chapter PRESELECTION 1 MENU.

5.15 Serial Menu

This menu defines the basic settings of serial interface.

This function is only available for devices with option Control- and Analog-Output.

| UNIT NUMMER | | |
|---|-----------|------------------|
| This parameter defines serial device addresses. The addresses between 11 and 99 can be assigned to the devices. Addresses with zero are not allowed, there are used as broadcast addresses. | | |
| | 11 | Smallest address |
| | ... | |
| | 99 | Highest address |

| SERIAL BAUD RATE | | |
|---|--------------|------------|
| This parameter defines the serial baud rate | | |
| 0 | 9600 | 9600 baud |
| 1 | 19200 | 19200 baud |
| 2 | 38400 | 38400 baud |

| SERIAL FORMAT | | | | |
|---|-----------------|--------|-------------|---------|
| This parameter defines the bit data format. | | | | |
| 0 | 7-EVEN-1 | 7 data | Parity even | 1 Stop |
| 1 | 7-EVEN-2 | 7 data | Parity even | 2 Stops |
| 2 | 7-ODD-1 | 7 data | Parity odd | 1 Stop |
| 3 | 7-ODD-2 | 7 data | Parity odd | 2 Stops |
| 4 | 7-NONE-1 | 7 data | no Parity | 1 Stop |
| 5 | 7-NONE-2 | 7 data | no Parity | 2 Stops |
| 6 | 8-EVEN-1 | 8 data | Parity even | 1 Stop |
| 7 | 8-ODD-1 | 8 data | Parity odd | 1 Stop |
| 8 | 8-NONE-1 | 8 data | no Parity | 1 Stop |
| 9 | 8-NONE-2 | 8 data | no Parity | 2 Stops |

| SERIAL INIT | | |
|---|------------|--|
| This parameter defines the baud rate for the initialization to the user interface OS6.0. With settings larger than 9600 the initialization time can be reduced. | | |
| 0 | NO | Initialization with 9600 baud. Then the device operates with the value selected by the user. |
| 1 | YES | Initialization with the baud rate set by SERIAL BAUD RATE. Then the device operates with the value selected by the user. |

Continuation „Serial Menu“:

| SERIAL PROTOCOL | | | | | | | | | | | | | |
|--|---|-----|---|-----|---|---|---|---|----|----|----|----|----|
| <p>Determines the sequence of characters send, when using the serial output for cyclic data transmission under time control (xxxxxxx = value SERIAL VALUE). Setting „1“ removes the unit address from the string which allows a slight faster transmission cycle.</p> | | | | | | | | | | | | | |
| 0 | Transmission report = Unit Nr., +/-, data, LF, CR <table border="1" style="margin-left: auto; margin-right: auto;"> <tr> <td>1</td><td>1</td><td>+/-</td><td>X</td><td>X</td><td>X</td><td>X</td><td>X</td><td>X</td><td>X</td><td>LF</td><td>CR</td> </tr> </table> | 1 | 1 | +/- | X | X | X | X | X | X | X | LF | CR |
| 1 | 1 | +/- | X | X | X | X | X | X | X | LF | CR | | |
| 1 | Transmission report = +/-, data, LF, CR <table border="1" style="margin-left: auto; margin-right: auto;"> <tr> <td>+/-</td><td>X</td><td>X</td><td>X</td><td>X</td><td>X</td><td>X</td><td>X</td><td>X</td><td>LF</td><td>CR</td> </tr> </table> | +/- | X | X | X | X | X | X | X | X | LF | CR | |
| +/- | X | X | X | X | X | X | X | X | LF | CR | | | |

| SERIAL TIMER (S) | |
|--|--|
| <p>This register determines the cycle time in seconds for cycling transmission of SERIAL VALUE when using the serial output (on a serial request, the cycling transmission is stopped for 20 s).</p> | |
| 0.000 | All cyclic transmission is switched off. The unit will send data upon a serial request or with command SERIAL PRINT. |
| ... | |
| 60.000 | Cycle time in seconds. |

| SERIAL VALUE | | |
|---|------|--|
| This parameter defines the value to be transmitted. | | |
| Setting | Code | Register contents |
| 0 | :0 | Value input 1 |
| 1 | :1 | Value input 2 |
| 2 | :2 | Result of the linking of input1 and input 2 |
| 3 | :3 | Result totalizator 1 |
| 4 | :4 | Result totalizator 2 |
| 5 | :5 | Result of the linking of 1 and 2 with totalization |
| 6 | :6 | Minimum value input 1 |
| 7 | :7 | Maximum value input 1 |
| 8 | :8 | Minimum value input 2 |
| 9 | :9 | Maximum value input 2 |

| MODBUS | |
|--|---|
| <p>This parameter enables the Modbus protocol and determines the Modbus address. For details of the Modbus communication please refer to the additional manual R60045.0002.</p> | |
| 0 | Modbus disabled Serial interface is using Lecom protocol (Kübler default protocol) |
| 1 ... 247 | Modbus enabled: Serial interface is using Modbus RTU protocol The set value is the Modbus address of the device. |

5.16 Analog Out Menu

This menu defines the basic settings of the analog output. This function is only available for devices with option Analog Output.

| ANALOG SOURCE | | |
|---|------------------------|---|
| This parameter defines the reference source for the Analog Output | | |
| 0 | INPUT 1 | the reference source is input 1 |
| 1 | INPUT 2 | the reference source is input 1 |
| 2 | LINKAGE 1 – 2 | the reference source is the result of the linking of input1 and input 2 |
| 3 | INPUT 1 TOTAL | the reference source is input 1 with totalization |
| 4 | INPUT 2 TOTAL | the reference source is input 1 with totalization |
| 5 | LINKAGE TOTAL | the reference source is the result of the linking of input1 and input 2 with totalization |
| 6 | IO LINK VALUE 1 | the reference source is the process data out value 1 sent by the IO-Link master |
| 7 | IO LINK VALUE 2 | the reference source is the process data out value 2 sent by the IO-Link master |
| 8 | MINIMUM VALUE 1 | minimum value, the reference source is input 1 |
| 9 | MAXIMUM VALUE 1 | maximum value, the reference source is input 1 |
| 10 | MINIMUM VALUE 2 | minimum value, the reference source is input 2 |
| 11 | MAXIMUM VALUE 2 | maximum value, the reference source is input 2 |

The totalization depends on the operation mode. See chart in chapter IN 1 Totalization.

| ANALOG FORMAT | | |
|--|------------------|---------------|
| This parameter defines the output characteristics. The analogue output is proportional to the display value. | | |
| With setting ANALOG FORMAT (-10 ... +10 V) in MODE COUNTER the polarity of the analog output depends on the polarity of the display value. | | |
| 0 | -10...10V | -10 ... +10 V |
| 1 | 0...20MA | 0 ... 20 mA |
| 2 | 4...20MA | 4 ... 20 mA |

| ANALOG START | | |
|--|------------------|----------------------|
| This parameter defines the start value of the analog conversion. This start value is corresponding to the display value for an analog output of 0 V or 0/4 mA. | | |
| | -99999999 | Smallest start value |
| | 0 | Default value |
| | +99999999 | Highest start value |

| ANALOG END | | |
|--|------------------|--------------------|
| This parameter defines the end value of the analog conversion. This end value is corresponding to the display value for an analog output of (+/-) 10 V or 20 mA. | | |
| | -99999999 | Smallest end value |
| | 10000 | Default Wert |
| | +99999999 | Highest end value |

Continuation „Analog Out Menu“:

| ANALOG GAIN (%) | | |
|---|---------------|---------------|
| This parameter sets the maximum modulation. The ANALOG GAIN returns the max. Control of the analogue output in% related to (+/-) 10 V or 20 mA. | | |
| e. g. 102.00 corresponds to a conversion of 10.2 V or 20.4 mA, when the ANALOG END value is reached. | | |
| e. g. 95.00 corresponds to a conversion of 9.5 V or 18 mA, when the ANALOG END value is reached. | | |
| | 0.00 | Smallest gain |
| | 100.00 | Default value |
| | 110.00 | Highest gain |

| ANALOG OFFSET (%) | | |
|---|---------------|-----------------|
| This parameter defines the zero offset of the analog output. | | |
| e. g. 0.20 result in an offset of 0.02 V or 0.04 mA at ANALOG START value | | |
| | -99.99 | Smallest offset |
| | 0 | Default value |
| | +99.99 | Highest offset |

5.17 Command Menu

| INPUT 1 ACTION | | | |
|--|------------------|---|---------|
| This parameter defines the function of the input "Ctrl. In 1". | | | |
| 0 | NO | No function | |
| 1 | TARA INPUT 1 | Value of input 1 is stored as an OFFSET of input 1 | (d) |
| 2 | TARA INPUT 2 | Value of input 2 is stored as an OFFSET of input 2 | (d) |
| 3 | TARA INPUT 1+2 | Value of input 1 is stored as an OFFSET of input 1 Value of input 1 is stored as an OFFSET of input 1 | (d) |
| 4 | RESET TOTAL 1 | Value of totalizator 1 is reset to zero | (d) (s) |
| 5 | RESET TOTAL 2 | Value of totalizator 2 is reset to zero | (d) (s) |
| 6 | RESET TOTAL 1+2 | Value of totalizator 1 is reset to zero Value of totalizator 2 is reset to zero | (d) (s) |
| 7 | TEACH PRESEL. 1 | Value (SOURCE 1) is stored as PRESELECTION 1 | (d) |
| 8 | TEACH PRESEL. 2 | Value (SOURCE 2) is stored as PRESELECTION 2 | (d) |
| 9 | TEACH PRESEL. 3 | Value (SOURCE 3) is stored as PRESELECTION 3 | (d) |
| 10 | TEACH PRESEL. 4 | Value (SOURCE 4) is stored as PRESELECTION 4 | (d) |
| 11 | SCROLL DISPLAY | Display switching (see chapter Screen structure in operation) | (d) |
| 12 | RESET MIN/MAX | Reset the Min. / Max. values | (d) (s) |
| 13 | CLEAR LOOP TIME | N.A. | |
| 14 | ACTIVATE | N.A. | |
| 15 | STORE DATA | N.A. | |
| 16 | TESTPROGRAM | N.A. | |
| 17 | SET RED COLOR | Red display: Event-dependending change of the display color by a switching condition is possible (see PRESELECTION 1...4 MENU) | (d) |
| 18 | SET GREEN COLOR | Green display: Event-dependending change of the display color by a switching condition is possible (see PRESELECTION 1...4 MENU) | (d) |
| 19 | SET YELLOW COLOR | Yellow display: Event-dependending change of the display color by a switching condition is possible (see PRESELECTION 1...4 MENU) | (d) |
| 20 | FREEZE | Freezing the display value | (s) |
| 21 | KEY LOCK | Key looked touch screen | (s) |
| 22 | LOCK RELEASE | No latch for preselection | (d) |
| 23 | SERIAL PRINT | Send serial data, see SERIAL VALUE | (d) |
| 24 | START PRESELECT | N.A. | |
| 25 | ADD TO TOTAL 1 | Adds the current value of input 1 to INPUT 1 TOTAL | (d) |
| 26 | ADD TO TOTAL 2 | Adds the current value of input 2 to INPUT 2 TOTAL | (d) |
| 27 | INC. BRIGHTNESS | Display brightness is increased | (d) (s) |
| 28 | DEC. BRIGHTNESS | Display brightness is reduced | (d) (s) |

(s) = statistical characteristic (level evaluation)

INPUT CONFIG must be set to ACTIVE LOW/HIGH

(d) = dynamical characteristic (edge evaluation)

INPUT CONFIG must be set to RISING/FALLING EDGE

Continuation „Command Menu:“

INPUT 1 CONFIG

This parameter defines the switching characteristics of the input “Ctrl. In 1”.

| | | |
|---|--------------|------------------------------------|
| 0 | ACTIVE LOW | Active at „LOW“ (static) |
| 1 | ACTIVE HIGH | Active at „HIGH“ (static) |
| 2 | RISING EDGE | Activate at rising edge (dynamic) |
| 3 | FALLING EDGE | Activate at falling edge (dynamic) |

INPUT 2 ACTION

This parameter defines the function of the input “Ctrl. In 2”.

See parameter INPUT 1 ACTION

INPUT 2 CONFIG

This parameter defines the switching characteristics of the input “Ctrl. In 2”.

See parameter INPUT 1 CONFIG.

INPUT 3 ACTION

This parameter defines the function of the input “Ctrl. In 3”.

See parameter INPUT 1 ACTION.

INPUT 3 CONFIG

This parameter defines the switching characteristics of the input “Ctrl. In 3”.

See parameter INPUT 1 CONFIG.

5.18 Display Menu

Parameter changes become active only after closing the menu selection.

| START DISPLAY | | |
|---|------------------------|--|
| This parameter defines the start display after switching on the device. | | |
| 0 | SINGLE | Single-line display The source must be defined in SOURCE SINGLE |
| 1 | DUAL | Two-line display The sources must be defined in SOURCE DUAL TOP / DOWN. |
| 2 | DUAL WITH UNIT | Two-line display with units The sources must be defined in SOURCE DUAL TOP / DOWN. |
| 3 | LARGE | Large display (only with active parameter "LARGE DISPLAY") The source must be defined in SOURCE LARGE |
| 4 | QUICKSTART | Display with quick start function. (Only with option AO, CO, RL) |
| 5 | MINIMUM/MAXIMUM | Display with actual / minimum / maximum values of input 1 and input 2 |

| SOURCE SINGLE (Reference source for single-line display) | | |
|---|------------------------|---|
| 0 | INPUT 1 | the reference source is input 1 |
| 1 | INPUT 2 | the reference source is input 2 |
| 2 | LINKAGE 1 – 2 | the reference source is the result of the linking of input1 and input 2 |
| 3 | INPUT 1 TOTAL | the reference source is input 1 with totalization |
| 4 | INPUT 2 TOTAL | the reference source is input 2 with totalization |
| 5 | LINKAGE TOTAL | the reference source is the result of the linking of input1 and input 2 with totalization |
| 6 | IO LINK VALUE 1 | the reference source is the process data out value 1 sent by the IO-Link master |
| 7 | IO LINK VALUE 2 | the reference source is the process data out value 2 sent by the IO-Link master |
| 8 | MINIMUM VALUE 1 | minimum value, the reference source is input 1 |
| 9 | MAXIMUM VALUE 1 | maximum value, the reference source is input 1 |
| 10 | MINIMUM VALUE 2 | minimum value, the reference source is input 2 |
| 11 | MAXIMUM VALUE 2 | maximum value, the reference source is input 2 |

| SOURCE DUAL TOP (Reference source for two-line display, first line) | | |
|--|----------------------|---|
| 0 | INPUT 1 | the reference source is input 1 |
| 1 | INPUT 2 | the reference source is input 2 |
| 2 | LINKAGE 1 – 2 | the reference source is the result of the linking of input1 and input 2 |
| 3 | INPUT 1 TOTAL | the reference source is input 1 with totalization |
| 4 | INPUT 2 TOTAL | the reference source is input 2 with totalization |

| | | |
|----|------------------------|---|
| 5 | LINKAGE TOTAL | the reference source is the result of the linking of input1 and input 2 with totalization |
| 6 | IO LINK VALUE 1 | the reference source is the process data out value 1 sent by the IO-Link master |
| 7 | IO LINK VALUE 2 | the reference source is the process data out value 2 sent by the IO-Link master |
| 8 | MINIMUM VALUE 1 | minimum value, the reference source is input 1 |
| 9 | MAXIMUM VALUE 1 | maximum value, he reference source is input 1 |
| 10 | MINIMUM VALUE 2 | minimum value, the reference source is input 2 |
| 11 | MAXIMUM VALUE 2 | maximum value, he reference source is input 2 |

SOURCE DUAL DOWN (Reference source for two-line display, second line)

| | | |
|----|------------------------|---|
| 0 | INPUT 1 | the reference source is input 1 |
| 1 | INPUT 2 | the reference source is input 2 |
| 2 | LINKAGE 1 – 2 | the reference source is the result of the linking of input1 and input 2 |
| 3 | INPUT 1 TOTAL | the reference source is input 1 with totalization |
| 4 | INPUT 2 TOTAL | the reference source is input 2 with totalization |
| 5 | LINKAGE TOTAL | the reference source is the result of the linking of input1 and input 2 with totalization |
| 6 | IO LINK VALUE 1 | the reference source is the process data out value 1 sent by the IO-Link master |
| 7 | IO LINK VALUE 2 | the reference source is the process data out value 2 sent by the IO-Link master |
| 8 | MINIMUM VALUE 1 | minimum value, the reference source is input 1 |
| 9 | MAXIMUM VALUE 1 | maximum value, he reference source is input 1 |
| 10 | MINIMUM VALUE 2 | minimum value, the reference source is input 2 |
| 11 | MAXIMUM VALUE 2 | maximum value, he reference source is input 2 |

LARGE DISPLAY

This parameter is used to turn on or off the large display window. Using the divider ratio, the large display value can also be divided.

| | | |
|----------|----------------|--|
| 0 | NO | Large display is switched off |
| 1 | 1:1 | Large display with divider ratio 1:1 |
| 2 | 1:10 | Large display with divider ratio 1:10 |
| 3 | 1:100 | Large display with divider ratio 1:100 |
| 4 | 1:1000 | Large display with divider ratio 1:1000 |
| 5 | 1:10000 | Large display with divider ratio 1:10000 |

SOURCE LARGE (Reference source for large display)

Parameter only visible with activated parameter "LARGE DISPLAY".

| | | |
|-----------|------------------------|---|
| 0 | INPUT 1 | the reference source is input 1 |
| 1 | INPUT 2 | the reference source is input 2 |
| 2 | LINKAGE 1 – 2 | the reference source is the result of the linking of input1 and input 2 |
| 3 | INPUT 1 TOTAL | the reference source is input 1 with totalization |
| 4 | INPUT 2 TOTAL | the reference source is input 2 with totalization |
| 5 | LINKAGE TOTAL | the reference source is the result of the linking of input1 and input 2 with totalization |
| 6 | IO LINK VALUE 1 | the reference source is the process data out value 1 sent by the IO-Link master |
| 7 | IO LINK VALUE 2 | the reference source is the process data out value 2 sent by the IO-Link master |
| 8 | MINIMUM VALUE 1 | minimum value, the reference source is input 1 |
| 9 | MAXIMUM VALUE 1 | maximum value, the reference source is input 1 |
| 10 | MINIMUM VALUE 2 | minimum value, the reference source is input 2 |
| 11 | MAXIMUM VALUE 2 | maximum value, the reference source is input 2 |

The totalization depends on the operation mode. See chart in chapter IN 1 Totalization.

Continuation „ Display Menu“:

COLOR

This parameter defines the display color.

Event-dependending change of the display color by a switching condition is possible (see PRESELECTION 1...4 MENU)

Event-dependending changes are only available for devices with option Control-, Analog- or Relay-Output.

| | | | |
|--|----------|---------------|----------------|
| | 0 | RED | Red display |
| | 1 | GREEN | Green display |
| | 2 | YELLOW | Yellow display |

BRIGHTNESS (%)

This parameter defines the brightness of the display in percent

| | | |
|--|------------|-----------------|
| | 10 | Min. brightness |
| | 80 | Default value |
| | 100 | Max. brightness |

CONTRAST

This parameter defines the viewing angle.

| | | |
|--|----------|---------------------------|
| | 0 | Viewing angle from top |
| | 1 | Viewing angle from center |
| | 2 | Viewing angle from bottom |

SCREEN SAVER (S)

This parameter defines the time in seconds until the display is switched off, after the last touch action. A new touch action will activate the display again.

| | | |
|--|-------------|----------------------------|
| | 0 | No switch off |
| | ... | |
| | 9999 | Longest time to switch off |

UP-DATE-TIME (S)

This parameter defines the update time in seconds of the display only.

| | | |
|--|--------------|----------------------|
| | 0.005 | Shortest update time |
| | 0.1 | Default value |
| | 9.999 | Longest update time |

FONT

This parameter defines the setting of the font style.

| | | |
|--|----------|----------|
| | 0 | Standard |
| | 1 | Font 1 |

6 Appendix

6.1 Data readout via serial interface

All codes shown in the parameter SERIAL VALUE are available for serial readout by PC or PLC. The communication of the Kübler devices is based on the Drivecom protocol according to ISO 1745 or the Modbus RTU protocol. All protocol details can be found in our manual SERPRO (Drivecom) which is available for download from our homepage www.kuebler.com and in the chapter “Modbus RTU Interface” in this manual.

To request for a data transmission you must send the following request string to the converter:

| | | | | | |
|-----|-----|-----|----|----|-----|
| EOT | AD1 | AD2 | C1 | C2 | ENQ |
|-----|-----|-----|----|----|-----|

EOT = control character (Hex 04)

AD1 = unit address, High Byte

AD2 = unit address, Low Byte

C1 = register code, High Byte

C2 = register code, Low Byte

ENQ = control character (Hex 05)

The following example shows the request string for readout of the actual input frequency of a monitor (Code :1) from a unit with unit address 11:

| | | | | | | |
|--------------|-----------|-----------|-----------|-----------|-----------|-----------|
| ASCII-Code: | EOT | 1 | 1 | : | 1 | ENQ |
| Hex-Code: | 04 | 31 | 31 | 3A | 31 | 05 |
| Binary-Code: | 0000 0100 | 0011 0001 | 0011 0001 | 0011 1010 | 0011 0001 | 0000 0101 |

After a correct request, the unit will respond:

| | | | | | |
|-----|----|----|-------|-----|-----|
| STX | C1 | C2 | xxxxx | ETX | BCC |
|-----|----|----|-------|-----|-----|

STX = control character (Hex 02)

C1 = register code, High Byte

C2 = register code, Low Byte

xxxxx = readout data

ETX = control character (Hex 03)

BCC = block check character

6.2 Modbus RTU Interface

The Modbus interface of the 57xT series is a standard Modbus RTU Slave and provides the following Modbus functions:

- Read Coils
- Write Single Coil
- Read Holding Registers
- Write Multiple Registers
- Diagnosis

For the operation of the interface module and the understanding of this manual basic knowledge in Modbus RTU communication is presupposed.

6.2.1 Parameter setting

Required parameter settings in 6.571T.XXX.X0X / 6.571T.XXX.XAX “Serial menu”:

| |
|---|
| <p>UNIT NUMMER Not valid for Modbus communication (For setting of Modbus address see parameter “MODBUS”)</p> |
|---|

| | | | | | | | | | |
|--|--------------|-------------|-----------|----------|--------------|------------|----------|--------------|------------|
| <p>SERIAL BAUD RATE This parameter defines the serial baud rate</p> | | | | | | | | | |
| <table border="1"> <tr> <td>0</td> <td>9600</td> <td>9600 baud</td> </tr> <tr> <td>1</td> <td>19200</td> <td>19200 baud</td> </tr> <tr> <td>2</td> <td>38400</td> <td>38400 baud</td> </tr> </table> | 0 | 9600 | 9600 baud | 1 | 19200 | 19200 baud | 2 | 38400 | 38400 baud |
| 0 | 9600 | 9600 baud | | | | | | | |
| 1 | 19200 | 19200 baud | | | | | | | |
| 2 | 38400 | 38400 baud | | | | | | | |

| | | | | | | | | | | | | | | | | | | | | | | | | | | | | | | | | | | |
|--|-----------------|---------------------------------|---------------------------------|-------------|-----------------|----------|----------------|----------|----------------|----------|-----------------|----------|-----------------|--|----------|-----------------|-------------|-------------|------------|----------|----------------|-------------|------------|------------|----------|-----------------|---------------------------------|--|--|----------|-----------------|-------------|-----------|-------------|
| <p>SERIAL FORMAT This parameter defines the bit data format.</p> | | | | | | | | | | | | | | | | | | | | | | | | | | | | | | | | | | |
| <table border="1"> <tr> <td>0</td> <td>7-EVEN-1</td> <td rowspan="5">Do not use with Modbus protocol</td> </tr> <tr> <td>1</td> <td>7-EVEN-2</td> </tr> <tr> <td>2</td> <td>7-ODD-1</td> </tr> <tr> <td>3</td> <td>7-ODD-2</td> </tr> <tr> <td>4</td> <td>7-NONE-1</td> </tr> <tr> <td>5</td> <td>7-NONE-2</td> <td></td> </tr> <tr> <td>6</td> <td>8-EVEN-1</td> <td>8 data bits</td> <td>Parity even</td> <td>1 stop bit</td> </tr> <tr> <td>7</td> <td>8-ODD-1</td> <td>8 data bits</td> <td>Parity odd</td> <td>1 stop bit</td> </tr> <tr> <td>8</td> <td>8-NONE-1</td> <td colspan="3">Do not use with Modbus protocol</td> </tr> <tr> <td>9</td> <td>8-NONE-2</td> <td>8 data bits</td> <td>no Parity</td> <td>2 stop bits</td> </tr> </table> | 0 | 7-EVEN-1 | Do not use with Modbus protocol | 1 | 7-EVEN-2 | 2 | 7-ODD-1 | 3 | 7-ODD-2 | 4 | 7-NONE-1 | 5 | 7-NONE-2 | | 6 | 8-EVEN-1 | 8 data bits | Parity even | 1 stop bit | 7 | 8-ODD-1 | 8 data bits | Parity odd | 1 stop bit | 8 | 8-NONE-1 | Do not use with Modbus protocol | | | 9 | 8-NONE-2 | 8 data bits | no Parity | 2 stop bits |
| 0 | 7-EVEN-1 | Do not use with Modbus protocol | | | | | | | | | | | | | | | | | | | | | | | | | | | | | | | | |
| 1 | 7-EVEN-2 | | | | | | | | | | | | | | | | | | | | | | | | | | | | | | | | | |
| 2 | 7-ODD-1 | | | | | | | | | | | | | | | | | | | | | | | | | | | | | | | | | |
| 3 | 7-ODD-2 | | | | | | | | | | | | | | | | | | | | | | | | | | | | | | | | | |
| 4 | 7-NONE-1 | | | | | | | | | | | | | | | | | | | | | | | | | | | | | | | | | |
| 5 | 7-NONE-2 | | | | | | | | | | | | | | | | | | | | | | | | | | | | | | | | | |
| 6 | 8-EVEN-1 | 8 data bits | Parity even | 1 stop bit | | | | | | | | | | | | | | | | | | | | | | | | | | | | | | |
| 7 | 8-ODD-1 | 8 data bits | Parity odd | 1 stop bit | | | | | | | | | | | | | | | | | | | | | | | | | | | | | | |
| 8 | 8-NONE-1 | Do not use with Modbus protocol | | | | | | | | | | | | | | | | | | | | | | | | | | | | | | | | |
| 9 | 8-NONE-2 | 8 data bits | no Parity | 2 stop bits | | | | | | | | | | | | | | | | | | | | | | | | | | | | | | |

Continuation “Parameter setting”

SERIAL INIT
Not valid for Modbus communication

SERIAL PROTOCOL
Not valid for Modbus communication

SERIAL TIMER (S)
Not valid for Modbus communication

SERIAL VALUE
Not valid for Modbus communication

| | |
|---|--|
| MODBUS | |
| This parameter enables the Modbus protocol and determines the Modbus address. | |
| 0 | Do not use for Modbus protocol (Modbus disabled) |
| 1 ... 247 | Modbus enabled: Serial interface is using Modbus RTU protocol The number set here determines the Modbus node address. |

6.2.2 Modbus Communication

The following Modbus functions are available:

6.2.2.1 Read Holding Registers and Write Multiple Registers

With the functions “Read Holding Registers” and “Write Multiple Registers” it is possible to access all registers of the device.

All variables (actual data) and status registers are mapped to Modbus Holding Registers. However, as all registers of the device are 32 bit registers but Modbus Holding registers are only 16 bit registers, each register of the device requires two Holding registers. (For this reason the use of Modbus function “Write Single Register” is not possible.) It is only possible to access to one single register of the 57xT device by each read or write operation, therefore the “Quantity (or number) of registers” in the Modbus request must always be 2.

Access to parameters

Holding Register 0x0000 / 0x0001 hex and following allow access to the device parameters.

The holding register numbers for a certain parameter can be calculated by the parameter # that can be found in the parameter table in the 57xT device manual:

Holding Register low = (parameter #) x 2

Holding Register high = (parameter #) x 2 + 1

Example:

Access to parameter # 51 “PRESELECTION 1” by Holding Register 0x0066 and 0x0067 hex.

Access to actual data

Holding Register 0x1000 / 0x1001 hex and following allow access to variables of the device (actual data registers):

Holding Register 0x1000 / 0x1001 hex → Actual data with serial Code “:0” (Display value)

Holding Register 0x1002 / 0x1003 hex → Actual data with serial Code “:1”

Holding Register 0x1004 / 0x1005 hex → Actual data with serial Code “:2”

Holding Register 0x1006 / 0x1007 hex → Actual data with serial Code “:3”

etc.

Access to status registers

Holding Register 0x2000 / 0x2001 hex and following allow access to status registers of the device:

Holding Register 0x2000 / 0x2001 hex → Output Status (Ctrl. Out status, read only)

Holding Register 0x2002 / 0x2003 hex → Serial Commands

Holding Register 0x2004 / 0x2005 hex → External Command (Ctrl. In status, read only)

Holding Register 0x2006 / 0x2007 hex → All Commands (read only)

6.2.2.2 Read Coils and Write Single Coil

With the functions “Read Coils” and “Write Single Coil” it is possible to read and set/reset single commands:

| Coil number | Serial code of command | Command | |
|-------------|------------------------|--|---|
| 0 | 54 | Reset / Set | Reset/Set Value |
| 1 | 55 | Freeze Display | Freeze actual display value |
| 2 | 56 | Touch Disable | Disable touch screen |
| 3 | 57 | Clear Lock | Loosen locking of all outputs / relay |
| 4 | 58 | Clear Min/Max | Reset of the min. / max. values |
| 5 | 59 | Serial Print (do not use with Modbus) | Sending of serial data |
| 6 | 60 | Teach Preset 1 | Current display value is stored as PRESELECTION 1 |
| 7 | 61 | Teach Preset 2 | Current display value is stored as PRESELECTION 2 |
| 8 | 62 | Teach Preset 3 | Current display value is stored as PRESELECTION 3 |
| 9 | 63 | Teach Preset 4 | Current display value is stored as PRESELECTION 4 |
| 10 | 64 | Scroll Display | Display switching (see display in operation mode) |
| 11 | 65 | Clear Loop Time | Release all latched switching conditions |
| 12 | 66 | Start Preselection | The preselection starts |
| 13 | 67 | Activate Data (not required with Modbus) | The data is activated. |
| 14 | 68 | Store to EEPROM | Store to EEPROM |
| 15 | 69 | Testprogram (do not use with Modbus) | Testprogram (do not use with Modbus) |

6.2.3 Diagnostics

The device supports the diagnostics subfunction 00 "Return Query Data". Other diagnostics functions are not available.

6.3 IO-Link Modul

This document is an additional description of the device 573T with the option IO. A device with this additional option is required to use this device description. It contains important notes and information regarding IO-link communication data. In addition to general information about the IO link connection, it includes the parameter data of the device, the exchanged process data, as well as the implemented system commands and error codes.

6.3.1 Communications data

| Parameters | Value |
|---------------------|---|
| Communication speed | COM 3 |
| Transmission rate | 230,4 kbit/s |
| IO-Link Revision | V1.1 |
| Cycle time | min. 3 ms |
| Portklasse | Class A  Important: The display device (IO-link device) must always be connected to a separate power supply (AC or DC)! |

6.3.2 Features

| Feature | Supported |
|-----------------------|-----------|
| Block parametrisation | Yes |
| Data Storage | Yes |
| SIO Mode | No |

6.3.3 IO-Link interface

Usuable IO-Link-Master

All IO-Link-masters, which support IO-link Standard v 1.1.

Connection of the IO-link interface

At terminal 34 (L-) and terminal 35 (L +) the supply voltage of the IO-link interface and at terminal 36 (c/q) the IO-link data line is connected to the port of the IO-link-master. Figure 1 shows the pin assignment of a standard M12 connection plug.

The display device (IO-link device) must also always be connected to a separate power supply (AC or DC).

| Assignment | | |
|---|-------|------------------------|
|  | Pin 1 | L+ (+24V) |
| | Pin 2 | Not connected |
| | Pin 3 | GND, L- |
| | Pin 4 | IO-Link data line, C/Q |

Fig. 1: Pin assignement M12 connection plug

| Pin | Wire color |
|----------|------------|
| 1 (L+) | brown |
| 2 (n.c.) | white |
| 3 (L-) | blue |
| 4 (C/Q) | black |

6.3.4 Parameter data

| ISDU Index | DPP1 Index | Name of the Parameter | Access | Length in bytes | Default Value | Range |
|----------------------------|------------|--------------------------|--------|-----------------|---|---------------|
| IDENTIFICATION MENU | | | | | | |
| | 7 | VendorID | R | 2 | 408 / 0x0198 | - |
| | 8 | | | | | |
| | 9 | Device ID | R | 3 | 1265669 / 0x135005 | - |
| | 10 | | | | | |
| | 11 | | | | | |
| 16 | | Vendor Name | R | 12 | Fritz Kübler GmbH | - |
| 17 | | Vendor Text | R | 21 | http://www.kuebler.com | - |
| 18 | | Product Name | R | 11 | Processcontroller | - |
| 19 | | Product ID | R | 5 | 573T | - |
| 20 | | Product Text | R | 35 | display unit with IO-Link interface | - |
| 21 | | Serial Number | R | 1 | - | - |
| 22 | | Hardware Revision | R | 7 | 350DX13 | - |
| 23 | | Firmware Revision | R | 7 | AX35004 | - |
| 24 | | Application Specific Tag | R/W | Max. 32 | *** | - |
| GENERAL MENU | | | | | | |
| 256 | | OPERATIONAL MODE | R/W | 4 | 0 | 0..5 |
| 257 | | PIN PRESELECTION | R/W | 4 | 0 | 0..9999 |
| 258 | | PIN PARAMETER | R/W | 4 | 0 | 0..9999 |
| 259 | | BACK UP MEMORY | R/W | 4 | 0 | 0..1 |
| 260 | | FACTORY SETTINGS | R/W | 4 | 0 | 0..1 |
| 261 | | ___ | R/W | 4 | 0 | 0..0 |
| 262 | | ___ | R/W | 4 | 0 | 0..0 |
| 263 | | ___ | R/W | 4 | 0 | 0..0 |
| 264 | | ___ | R/W | 4 | 0 | 0..0 |
| IN 1 PROPERTIES | | | | | | |
| 265 | | IN1 CONFIGURATION | R/W | 4 | 0 | 0..2 |
| 266 | | IN1 START VALUE | R/W | 4 | 0 | -99999..99999 |
| 267 | | IN1 END VALUE | R/W | 4 | 10000 | -99999..99999 |
| 268 | | IN1 DECIMAL POINT | R/W | 4 | 3 | 0..7 |
| 269 | | IN1 SCALE UNITS | R/W | 4 | 0 | 0..29 |
| 270 | | IN1 SAMPLING TIME (S) | R/W | 4 | 10 | 1..60000 |
| 271 | | IN1 AVERAGE FILTER | R/W | 4 | 0 | 0..4 |
| 272 | | IN1 OFFSET | R/W | 4 | 0 | -99999..99999 |
| 273 | | IN1 LINEARIZATION | R/W | 4 | 0 | 0..2 |
| 274 | | IN1 TOTALIZATION | R/W | 4 | 0 | 0..1 |
| 275 | | ___ | R/W | 4 | 0 | 0..0 |
| 276 | | ___ | R/W | 4 | 0 | 0..0 |
| 277 | | ___ | R/W | 4 | 0 | 0..0 |

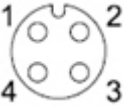
| ISDU Index | DPP1 Index | Name of the Parameter | Access | Length in bytes | Default Value | Range |
|---------------------------|------------|-----------------------|--------|-----------------|---------------|-------------------------|
| IN 1 LINEARIZATION | | | | | | |
| 278 | | IN1 LIN P1(X) | R/W | 4 | 0 | - 99999999..99999999 |
| 279 | | IN1 LIN P1(Y) | R/W | 4 | 0 | - 99999999..99999999 |
| 280 | | IN1 LIN P2(X) | R/W | 4 | 0 | - 99999999..99999999 |
| 281 | | IN1 LIN P2(Y) | R/W | 4 | 0 | - 99999999..99999999 |
| 282 | | IN1 LIN P3(X) | R/W | 4 | 0 | - 99999999..99999999 |
| 283 | | IN1 LIN P3(Y) | R/W | 4 | 0 | - 99999999..99999999 |
| 284 | | IN1 LIN P4(X) | R/W | 4 | 0 | - 99999999..99999999 |
| 285 | | IN1 LIN P4(Y) | R/W | 4 | 0 | - 99999999..99999999 |
| 286 | | IN1 LIN P5(X) | R/W | 4 | 0 | - 99999999..99999999 |
| 287 | | IN1 LIN P5(Y) | R/W | 4 | 0 | - 99999999..99999999 |
| 288 | | IN1 LIN P6(X) | R/W | 4 | 0 | - 99999999..99999999 |
| 289 | | IN1 LIN P6(Y) | R/W | 4 | 0 | - 99999999..99999999 |
| 290 | | IN1 LIN P7(X) | R/W | 4 | 0 | - 99999999..99999999 |
| 291 | | IN1 LIN P7(Y) | R/W | 4 | 0 | - 99999999..99999999 |
| 292 | | IN1 LIN P8(X) | R/W | 4 | 0 | - 99999999..99999999 |
| 293 | | IN1 LIN P8(Y) | R/W | 4 | 0 | - 99999999..99999999 |
| 294 | | IN1 LIN P9(X) | R/W | 4 | 0 | - 99999999..99999999 |
| 295 | | IN1 LIN P9(Y) | R/W | 4 | 0 | - 99999999..99999999 |
| 296 | | IN1 LIN P10(X) | R/W | 4 | 0 | - 99999999..99999999 |
| 297 | | IN1 LIN P10(Y) | R/W | 4 | 0 | - 99999999..99999999 |
| 298 | | IN1 LIN P11(X) | R/W | 4 | 0 | - 99999999..99999999 |
| 299 | | IN1 LIN P11(Y) | R/W | 4 | 0 | - 99999999..99999999 |
| 300 | | IN1 LIN P12(X) | R/W | 4 | 0 | - 99999999..99999999 |
| 301 | | IN1 LIN P12(Y) | R/W | 4 | 0 | - 99999999..99999999 |

| | | | | | | |
|-----|--|----------------|-----|---|---|-------------------------|
| 302 | | IN1 LIN P13(X) | R/W | 4 | 0 | - 99999999..99999999 |
| 303 | | IN1 LIN P13(Y) | R/W | 4 | 0 | - 99999999..99999999 |

| ISDU Index | DPP1 Index | Name of the Parameter | Access | Length in bytes | Default Value | Range |
|------------|------------|-----------------------|--------|-----------------|---------------|-------------------------|
| 304 | | IN1 LIN P14(X) | R/W | 4 | 0 | - 99999999..99999999 |
| 305 | | IN1 LIN P14(Y) | R/W | 4 | 0 | - 99999999..99999999 |
| 306 | | IN1 LIN P15(X) | R/W | 4 | 0 | - 99999999..99999999 |
| 307 | | IN1 LIN P15(Y) | R/W | 4 | 0 | - 99999999..99999999 |
| 308 | | IN1 LIN P16(X) | R/W | 4 | 0 | - 99999999..99999999 |
| 309 | | IN1 LIN P16(Y) | R/W | 4 | 0 | - 99999999..99999999 |
| 310 | | IN1 LIN P17(X) | R/W | 4 | 0 | - 99999999..99999999 |
| 311 | | IN1 LIN P17(Y) | R/W | 4 | 0 | - 99999999..99999999 |
| 312 | | IN1 LIN P18(X) | R/W | 4 | 0 | - 99999999..99999999 |
| 313 | | IN1 LIN P18(Y) | R/W | 4 | 0 | - 99999999..99999999 |
| 314 | | IN1 LIN P19(X) | R/W | 4 | 0 | - 99999999..99999999 |
| 315 | | IN1 LIN P19(Y) | R/W | 4 | 0 | - 99999999..99999999 |
| 316 | | IN1 LIN P20(X) | R/W | 4 | 0 | - 99999999..99999999 |
| 317 | | IN1 LIN P20(Y) | R/W | 4 | 0 | - 99999999..99999999 |
| 318 | | IN1 LIN P21(X) | R/W | 4 | 0 | - 99999999..99999999 |
| 319 | | IN1 LIN P21(Y) | R/W | 4 | 0 | - 99999999..99999999 |
| 320 | | IN1 LIN P22(X) | R/W | 4 | 0 | - 99999999..99999999 |
| 321 | | IN1 LIN P22(Y) | R/W | 4 | 0 | - 99999999..99999999 |
| 322 | | IN1 LIN P23(X) | R/W | 4 | 0 | - 99999999..99999999 |
| 323 | | IN1 LIN P23(Y) | R/W | 4 | 0 | - 99999999..99999999 |
| 324 | | IN1 LIN P24(X) | R/W | 4 | 0 | - 99999999..99999999 |

| | | | | | | |
|--------------------------|--|---------------------------|-----|---|---|-------------------------|
| 325 | | IN1 LIN P24(Y) | R/W | 4 | 0 | - 99999999..99999999 |
| IN 1 TOTALIZATION | | | | | | |
| 326 | | IN 1 TOT BASE | R/W | 4 | 0 | 0..3 |
| 327 | | IN 1 TOT DIVIDER | R/W | 4 | 0 | 0..3 |
| 328 | | IN 1 TOT DECIMAL POINT | R/W | 4 | 0 | 0..7 |
| 329 | | IN 1 TOT SCALE UNITS | R/W | 4 | 0 | 0..29 |
| 330 | | --- | R/W | 4 | 0 | 0..0 |
| 331 | | --- | R/W | 4 | 0 | 0..0 |
| 332 | | --- | R/W | 4 | 0 | 0..0 |

| ISDU Index | DPP1 Index | Name of the Parameter | Access | Length in bytes | Default Value | Range |
|---------------------------|---------------|--------------------------|--------|--------------------|---------------|-------------------------|
| IN 2 PROPERTIES | | | | | | |
| 333 | | IN2 CONFIGURATION | R/W | 4 | 0 | 0..2 |
| 334 | | IN2 START VALUE | R/W | 4 | 0 | -99999..99999 |
| 335 | | IN2 END VALUE | R/W | 4 | 10000 | -99999..99999 |
| 336 | | IN2 DECIMAL POINT | R/W | 4 | 3 | 0..7 |
| 337 | | IN2 SCALE UNITS | R/W | 4 | 0 | 0..29 |
| 338 | | IN2 SAMPLING TIME (S) | R/W | 4 | 10 | 1..60000 |
| 339 | | IN2 AVERAGE FILTER | R/W | 4 | 0 | 0..4 |
| 340 | | IN2 OFFSET | R/W | 4 | 0 | -99999..99999 |
| 341 | | IN2 LINEARIZATION | R/W | 4 | 0 | 0..2 |
| 342 | | IN2 TOTALIZATION | R/W | 4 | 0 | 0..1 |
| 343 | | --- | R/W | 4 | 0 | 0..0 |
| 344 | | --- | R/W | 4 | 0 | 0..0 |
| 345 | | --- | R/W | 4 | 0 | 0..0 |
| IN 2 LINEARIZATION | | | | | | |
| 346 | | IN2 LIN P1(X) | R/W | 4 | 0 | - 99999999..99999999 |
| 347 | | IN2 LIN P1(Y) | R/W | 4 | 0 | - 99999999..99999999 |
| 348 | | IN2 LIN P2(X) | R/W | 4 | 0 | - 99999999..99999999 |
| 349 | | IN2 LIN P2(Y) | R/W | 4 | 0 | - 99999999..99999999 |
| 350 | | IN2 LIN P3(X) | R/W | 4 | 0 | - 99999999..99999999 |
| 351 | | IN2 LIN P3(Y) | R/W | 4 | 0 | - 99999999..99999999 |
| 352 | | IN2 LIN P4(X) | R/W | 4 | 0 | - 99999999..99999999 |
| 353 | | IN2 LIN P4(Y) | R/W | 4 | 0 | - 99999999..99999999 |
| 354 | | IN2 LIN P5(X) | R/W | 4 | 0 | - 99999999..99999999 |

| | | | | | | |
|-----|--|---------------|-----|---|---|-------------------------|
| 355 | | IN2 LIN P5(Y) | R/W | 4 | 0 | - 99999999..99999999 |
| 356 | | IN2 LIN P6(X) | R/W | 4 | 0 | - 99999999..99999999 |
| 357 | | IN2 LIN P6(Y) | R/W | 4 | 0 | - 99999999..99999999 |
| 358 | | IN2 LIN P7(X) | R/W | 4 | 0 | - 99999999..99999999 |
| 359 | | IN2 LIN P7(Y) | R/W | 4 | 0 | - 99999999..99999999 |
| 360 | | IN2 LIN P8(X) | R/W | 4 | 0 | - 99999999..99999999 |
| 361 | | IN2 LIN P8(Y) | R/W | 4 | 0 | - 99999999..99999999 |
| 362 | | IN2 LIN P9(X) | R/W | 4 | 0 | - 99999999..99999999 |
| 363 | | IN2 LIN P9(Y) | R/W | 4 | 0 | - 99999999..99999999 |

| ISDU Index | DPP1 Index | Name of the Parameter | Access | Length in bytes | Default Value | Range |
|------------|------------|-----------------------|--------|-----------------|---------------|-------------------------|
| 364 | | IN2 LIN P10(X) | R/W | 4 | 0 | - 99999999..99999999 |
| 365 | | IN2 LIN P10(Y) | R/W | 4 | 0 | - 99999999..99999999 |
| 366 | | IN2 LIN P11(X) | R/W | 4 | 0 | - 99999999..99999999 |
| 367 | | IN2 LIN P11(Y) | R/W | 4 | 0 | - 99999999..99999999 |
| 368 | | IN2 LIN P12(X) | R/W | 4 | 0 | - 99999999..99999999 |
| 369 | | IN2 LIN P12(Y) | R/W | 4 | 0 | - 99999999..99999999 |
| 370 | | IN2 LIN P13(X) | R/W | 4 | 0 | - 99999999..99999999 |
| 371 | | IN2 LIN P13(Y) | R/W | 4 | 0 | - 99999999..99999999 |
| 372 | | IN2 LIN P14(X) | R/W | 4 | 0 | - 99999999..99999999 |
| 373 | | IN2 LIN P14(Y) | R/W | 4 | 0 | - 99999999..99999999 |
| 374 | | IN2 LIN P15(X) | R/W | 4 | 0 | - 99999999..99999999 |
| 375 | | IN2 LIN P15(Y) | R/W | 4 | 0 | - 99999999..99999999 |
| 376 | | IN2 LIN P16(X) | R/W | 4 | 0 | - 99999999..99999999 |
| 377 | | IN2 LIN P16(Y) | R/W | 4 | 0 | - 99999999..99999999 |
| 378 | | IN2 LIN P17(X) | R/W | 4 | 0 | - 99999999..99999999 |
| 379 | | IN2 LIN P17(Y) | R/W | 4 | 0 | - 99999999..99999999 |
| 380 | | IN2 LIN P18(X) | R/W | 4 | 0 | - 99999999..99999999 |
| 381 | | IN2 LIN P18(Y) | R/W | 4 | 0 | - 99999999..99999999 |
| 382 | | IN2 LIN P19(X) | R/W | 4 | 0 | - 99999999..99999999 |
| 383 | | IN2 LIN P19(Y) | R/W | 4 | 0 | - 99999999..99999999 |
| 384 | | IN2 LIN P20(X) | R/W | 4 | 0 | - 99999999..99999999 |
| 385 | | IN2 LIN P20(Y) | R/W | 4 | 0 | - 99999999..99999999 |
| 386 | | IN2 LIN P21(X) | R/W | 4 | 0 | - 99999999..99999999 |

| | | | | | | |
|-----|--|----------------|-----|---|---|-------------------------|
| 387 | | IN2 LIN P21(Y) | R/W | 4 | 0 | - 99999999..99999999 |
| 388 | | IN2 LIN P22(X) | R/W | 4 | 0 | - 99999999..99999999 |
| 389 | | IN2 LIN P22(Y) | R/W | 4 | 0 | - 99999999..99999999 |

| ISDU Index | DPP1 Index | Name of the Parameter | Access | Length in bytes | Default Value | Range |
|------------|------------|-----------------------|--------|-----------------|---------------|-------------------------|
| 390 | | IN2 LIN P23(X) | R/W | 4 | 0 | - 99999999..99999999 |
| 391 | | IN2 LIN P23(Y) | R/W | 4 | 0 | - 99999999..99999999 |
| 392 | | IN2 LIN P24(X) | R/W | 4 | 0 | - 99999999..99999999 |
| 393 | | IN2 LIN P24(Y) | R/W | 4 | 0 | - 99999999..99999999 |

IN 2 TOTALIZATION

| | | | | | | |
|-----|--|-----------------------|-----|---|---|-------|
| 394 | | IN2 TOT BASE | R/W | 4 | 0 | 0..3 |
| 395 | | IN2 TOT DIVIDER | R/W | 4 | 0 | 0..3 |
| 396 | | IN2 TOT DECIMAL POINT | R/W | 4 | 0 | 0..7 |
| 397 | | IN2 TOT SCALE UNITS | R/W | 4 | 0 | 0..29 |
| 398 | | == | R/W | 4 | 0 | 0..0 |
| 399 | | == | R/W | 4 | 0 | 0..0 |
| 400 | | == | R/W | 4 | 0 | 0..0 |

LINKAGE PROPERTIES

| | | | | | | |
|-----|--|------------------------|-----|---|---|-------------------------|
| 401 | | LINKAGE FACTOR | R/W | 4 | 1 | - 99999999..99999999 |
| 402 | | LINKAGE DIVIDER | R/W | 4 | 1 | - 99999999..99999999 |
| 403 | | LINKAGE ADDITIVE VALUE | R/W | 4 | 0 | - 99999999..99999999 |
| 404 | | LINKAGE DECIMAL POINT | R/W | 4 | 0 | 0..7 |
| 405 | | LINKAGE SCALE UNITS | R/W | 4 | 0 | 0..29 |
| 406 | | == | R/W | 4 | 0 | 0..0 |
| 407 | | == | R/W | 4 | 0 | 0..0 |
| 408 | | == | R/W | 4 | 0 | 0..0 |

IO LINK PROPERTIES

| | | | | | | |
|-----|--|------------------------|-----|---|---|-------------------------|
| 409 | | IOL IN1 FACTOR | R/W | 4 | 1 | - 99999999..99999999 |
| 410 | | IOL IN1 DIVIDER | R/W | 4 | 1 | - 99999999..99999999 |
| 411 | | IOL IN1 ADDITIVE VALUE | R/W | 4 | 0 | - 99999999..99999999 |
| 412 | | IOL IN1 DECIMAL POINT | R/W | 4 | 0 | 0..7 |
| 413 | | IOL IN1 SCALE UNITS | R/W | 4 | 0 | 0..29 |

| 414 | | IOL IN2 FACTOR | R/W | 4 | 1 | - 99999999..99999999 |
|---------------------|------------|-------------------------|--------|-----------------|---------------|-------------------------|
| 415 | | IOL IN2 DIVIDER | R/W | 4 | 1 | - 99999999..99999999 |
| 416 | | IOL IN2 ADDITIVE VALUE | R/W | 4 | 0 | - 99999999..99999999 |
| 417 | | IOL IN2 DECIMAL POINT | R/W | 4 | 0 | 0..7 |
| 418 | | IOL IN2 SCALE UNITS | R/W | 4 | 0 | 0..29 |
| 419 | | ___ | R/W | 4 | 0 | 0..0 |
| 420 | | ___ | R/W | 4 | 0 | 0..0 |
| 421 | | ___ | R/W | 4 | 0 | 0..0 |
| 422 | | ___ | R/W | 4 | 0 | 0..0 |
| ISDU Index | DPP1 Index | Name of the Parameter | Access | Length in bytes | Default Value | Range |
| PRESELECTION VALUES | | | | | | |
| 423 | | PRESELECTION 1 | R/W | 4 | 1000 | - 99999999..99999999 |
| 424 | | PRESELECTION 2 | R/W | 4 | 2000 | - 99999999..99999999 |
| 425 | | PRESELECTION 3 | R/W | 4 | 3000 | - 99999999..99999999 |
| 426 | | PRESELECTION 4 | R/W | 4 | 4000 | - 99999999..99999999 |
| 427 | | ___ | R/W | 4 | 0 | 0..0 |
| 428 | | ___ | R/W | 4 | 0 | 0..0 |
| PRESELECTION 1 MENU | | | | | | |
| 429 | | PRES1 SOURCE 1 | R/W | 4 | 0 | 0..11 |
| 430 | | PRES1 MODE 1 | R/W | 4 | 0 | 0..6 |
| 431 | | PRES1 HYSTERESIS 1 | R/W | 4 | 0 | 0..99999 |
| 432 | | PRES1 PULSE TIME 1 | R/W | 4 | 0 | 0..60000 |
| 433 | | PRES1 OUTPUT TARGET 1 | R/W | 4 | 1 | 0..6 |
| 434 | | PRES1 OUTPUT POLARITY 1 | R/W | 4 | 0 | 0..1 |
| 435 | | PRES1 OUTPUT LOCK 1 | R/W | 4 | 0 | 0..1 |
| 436 | | PRES1 START UP DELAY 1 | R/W | 4 | 0 | 0..60000 |
| 437 | | PRES1 EVENT COLOR 1 | R/W | 4 | 0 | 0..3 |
| 438 | | ___ | R/W | 4 | 0 | 0..0 |
| 439 | | ___ | R/W | 4 | 0 | 0..0 |
| PRESELECTION 2 MENU | | | | | | |
| 440 | | PRES2 SOURCE 2 | R/W | 4 | 0 | 0..11 |
| 441 | | PRES2 MODE 2 | R/W | 4 | 0 | 0..6 |
| 442 | | PRES2 HYSTERESIS 2 | R/W | 4 | 0 | 0..99999 |
| 443 | | PRES2 PULSE TIME 2 | R/W | 4 | 0 | 0..60000 |
| 444 | | PRES2 OUTPUT TARGET 2 | R/W | 4 | 2 | 0..6 |
| 445 | | PRES2 OUTPUT | R/W | 4 | 0 | 0..1 |

| | | | | | | |
|----------------------------|-------------------|------------------------------|---------------|------------------------|----------------------|--------------|
| | | POLARITY 2 | | | | |
| 446 | | PRES2 OUTPUT LOCK 2 | R/W | 4 | 0 | 0..1 |
| 447 | | PRES2 START UP DELAY 2 | R/W | 4 | 0 | 0..60000 |
| 448 | | PRES2 EVENT COLOR 2 | R/W | 4 | 0 | 0..3 |
| 449 | | --- | R/W | 4 | 0 | 0..0 |
| 450 | | --- | R/W | 4 | 0 | 0..0 |
| PRESELECTION 3 MENU | | | | | | |
| 451 | | PRES3 SOURCE 3 | R/W | 4 | 0 | 0..11 |
| 452 | | PRES3 MODE 3 | R/W | 4 | 0 | 0..6 |
| 453 | | PRES3 HYSTERESIS 3 | R/W | 4 | 0 | 0..99999 |
| 454 | | PRES3 PULSE TIME 3 | R/W | 4 | 0 | 0..60000 |
| 455 | | PRES3 OUTPUT TARGET 3 | R/W | 4 | 3 | 0..6 |
| 456 | | PRES3 OUTPUT POLARITY 3 | R/W | 4 | 0 | 0..1 |
| 457 | | PRES3 OUTPUT LOCK 3 | R/W | 4 | 0 | 0..1 |
| 458 | | PRES3 START UP DELAY 3 | R/W | 4 | 0 | 0..1 |
| 459 | | PRES3 EVENT COLOR 3 | R/W | 4 | 0 | 0..3 |
| 460 | | --- | R/W | 4 | 0 | 0..0 |
| 461 | | --- | R/W | 4 | 0 | 0..0 |
| ISDU Index | DPP1 Index | Name of the Parameter | Access | Length in bytes | Default Value | Range |
| PRESELECTION 4 MENU | | | | | | |
| 462 | | PRES4 SOURCE 4 | R/W | 4 | 0 | 0..11 |
| 463 | | PRES4 MODE 4 | R/W | 4 | 0 | 0..6 |
| 464 | | PRES4 HYSTERESIS 4 | R/W | 4 | 0 | 0..99999 |
| 465 | | PRES4 PULSE TIME 4 | R/W | 4 | 0 | 0..60000 |
| 466 | | PRES4 OUTPUT TARGET 4 | R/W | 4 | 4 | 0..6 |
| 467 | | PRES4 OUTPUT POLARITY 4 | R/W | 4 | 0 | 0..1 |
| 468 | | PRES4 OUTPUT LOCK 4 | R/W | 4 | 0 | 0..1 |
| 469 | | PRES4 START UP DELAY 4 | R/W | 4 | 0 | 0..1 |
| 470 | | PRES4 EVENT COLOR 4 | R/W | 4 | 0 | 0..3 |
| 471 | | --- | R/W | 4 | 0 | 0..0 |
| 472 | | --- | R/W | 4 | 0 | 0..0 |
| SERIAL MENU | | | | | | |
| 473 | | UNIT NUMBER | R/W | 4 | 11 | 11..99 |
| 474 | | SERIAL BAUD RATE | R/W | 4 | 0 | 0..2 |
| 475 | | SERIAL FORMAT | R/W | 4 | 0 | 0..9 |
| 476 | | SERIAL INIT | R/W | 4 | 0 | 0..1 |
| 477 | | SERIAL PROTOCOL | R/W | 4 | 0 | 0..1 |
| 478 | | SERIAL TIMER | R/W | 4 | 0 | 0..60000 |
| 479 | | SERIAL VALUE | R/W | 4 | 0 | 0..9 |
| 480 | | MODBUS | R/W | 4 | 0 | 0..247 |

| | | | | | | |
|------------------------|--|-----------------|-----|---|-------|-------------------------|
| 481 | | ___ | R/W | 4 | 0 | 0..0 |
| ANALOG OUT MENU | | | | | | |
| 482 | | ANALOG SOURCE | R/W | 4 | 0 | 0..11 |
| 483 | | ANALOG FORMAT | R/W | 4 | 0 | 0..2 |
| 484 | | ANALOG START | R/W | 4 | 0 | - 99999999..99999999 |
| 485 | | ANALOG END | R/W | 4 | 10000 | - 99999999..99999999 |
| 486 | | ANALOG GAIN % | R/W | 4 | 10000 | 0..11000 |
| 487 | | ANALOG OFFSET % | R/W | 4 | 0 | -9999..9999 |
| 488 | | ___ | R/W | 4 | 0 | 0..0 |
| 489 | | ___ | R/W | 4 | 0 | 0..0 |
| COMMAND MENU | | | | | | |
| 490 | | INPUT 1 ACTION | R/W | 4 | 0 | 0..28 |
| 491 | | INPUT 1 CONFIG. | R/W | 4 | 2 | 0..3 |
| 492 | | INPUT 2 ACTION | R/W | 4 | 0 | 0..28 |
| 493 | | INPUT 2 CONFIG. | R/W | 4 | 2 | 0..3 |
| 494 | | INPUT 3 ACTION | R/W | 4 | 0 | 0..28 |
| 495 | | INPUT 3 CONFIG. | R/W | 4 | 2 | 0..3 |
| 496 | | ___ | R/W | 4 | 0 | 0..0 |
| 497 | | ___ | R/W | 4 | 0 | 0..0 |
| 498 | | ___ | R/W | 4 | 0 | 0..0 |
| 499 | | ___ | R/W | 4 | 0 | 0..0 |

| ISDU Index | DPP1 Index | Name of the Parameter | Access | Length in bytes | Default Value | Range |
|---------------------|------------|-----------------------|--------|-----------------|---------------|---------|
| DISPLAY MENU | | | | | | |
| 500 | | START DISPLAY | R/W | 4 | 0 | 0..5 |
| 501 | | SOURCE SINGLE | R/W | 4 | 0 | 0..11 |
| 502 | | SOURCE DUAL TOP | R/W | 4 | 0 | 0..11 |
| 503 | | SOURCE DUAL DOWN | R/W | 4 | 1 | 0..11 |
| 504 | | LARGE DISPLAY | R/W | 4 | 0 | 0..6 |
| 505 | | SOURCE LARGE | R/W | 4 | 0 | 0..11 |
| 506 | | COLOR | R/W | 4 | 0 | 0..2 |
| 507 | | BRIGHTNESS (%) | R/W | 4 | 80 | 10..100 |
| 508 | | CONTRAST | R/W | 4 | 1 | 0..2 |
| 509 | | SCREEN SAVER (s) | R/W | 4 | 0 | 0..9999 |
| 510 | | UP-DATE-TIME (ms) | R/W | 4 | 100 | 5..9999 |
| 511 | | FONT | R/W | 4 | 0 | 0..1 |
| 512 | | ___ | R/W | 4 | 0 | 0..0 |
| 513 | | ___ | R/W | 4 | 0 | 0..0 |
| 514 | | ___ | R/W | 4 | 0 | 0..0 |

6.3.5 System Commands

A system command is a write-only parameter that causes an action in the device. To invoke the desired action, the corresponding value must be written to index 2, subindex 0. If the desired command is a static command (s), this command remains active until the corresponding value is written again to index 2, subindex 0. By resending the command, the action is terminated.

6.3.5.1 Predefined commands

| Name | Index | Subindex | Value | Description of the action | Dynamic (d)/static (s) |
|--------------------------|-------|----------|-------|--|------------------------|
| RESTORE FACTORY SETTINGS | 2 | 0 | 130 | Reset all parameters to factory setting. | (d) |

6.3.5.2 Application specific commands

| Name | Index | Subindex | Value | Description of the action | Dynamic (d)/static (s) |
|----------------------|-------|----------|-------|--|------------------------|
| TARA INPUT 1 | 2 | 0 | 160 | Value of input 1 is stored as an offset from input 1. | (d) |
| TARA INPUT 2 | 2 | 0 | 161 | Value of input 2 is stored as an offset from input 2. | (d) |
| TARA INPUT 1 + 2 | 2 | 0 | 162 | Value of input 1 is stored as an offset from input 1, value of input 2 is stored as an offset from input 2 | (d) |
| ADD TO TOTAL 1 | 2 | 0 | 163 | Adds the current value from input 1 to INPUT 1 TOTAL. | (d) |
| ADD TO TOTAL 2 | 2 | 0 | 164 | Adds the current value from input 2 to INPUT 2 TOTAL. | (d) |
| RESET TOTAL 1 | 2 | 0 | 165 | Value of totalizator 1 is reset to 0. | (d) |
| RESET TOTAL 2 | 2 | 0 | 166 | Value of totalizator 2 is reset to 0. | (d) |
| RESET TOTAL LINKAGE | 2 | 0 | 167 | Value of totalizator 1 and 2 are reset to 0. | (d) |
| TEACH PRESELECTION 1 | 2 | 0 | 168 | Value (SOURCE 1) is saved as PRESELECTION 1. | (d) |
| TEACH PRESELECTION 2 | 2 | 0 | 169 | Value (SOURCE 2) is saved as PRESELECTION 2. | (d) |
| TEACH PRESELECTION 3 | 2 | 0 | 170 | Value (SOURCE 3) is saved as PRESELECTION 3. | (d) |
| TEACH PRESELECTION 4 | 2 | 0 | 171 | Value (SOURCE 4) is saved as PRESELECTION 4. | (d) |
| SCROLL DISPLAY | 2 | 0 | 172 | Display switching. | (d) |
| SERIAL PRINT | 2 | 0 | 173 | Send serial data, see SERIAL VALUE. | (d) |
| SET TO RED | 2 | 0 | 174 | Display lights up red. The color can be changed by the event-dependent color switching in the PRESELECTION 1 ... 4 MENU | (d) |
| SET TO GREEN | 2 | 0 | 175 | Display lights up green. The color can be changed by the event-dependent color switching in the PRESELECTION 1 ... 4 MENU | (d) |
| SET TO YELLOW | 2 | 0 | 176 | Display lights up yellow. The color can be changed by the event-dependent color switching in the PRESELECTION 1 ... 4 MENU | (d) |
| CLEAR MIN/MAX VALUES | 2 | 0 | 177 | Reset of min/MAX values | (s) |
| CLEAR LOOP TIME | 2 | 0 | 178 | Loop time Reset | (d) |

| | | | | | |
|---------------|---|---|-----|---|-----|
| ACTIVATE DATA | 2 | 0 | 179 | N.A. | (d) |
| STORE EEPROM | 2 | 0 | 180 | Current parameter set is stored non-volatile in the EEPROM. | (d) |
| TESTPROGRAMM | 2 | 0 | 181 | Starts or stops the test program | (s) |
| FREEZE | 2 | 0 | 182 | Freeze the display value. | (s) |
| KEY LOCK | 2 | 0 | 183 | Keypad Lock: Touchscreen. | (s) |
| LOCK RELEASE | 2 | 0 | 184 | Self-locking of all outputs/relays. | (d) |

6.3.6 IO-Link Prozessdaten

6.3.6.1 Process input (32 bytes)

View from the IO-link master!

| Byte | Bit | Function | Logic |
|---------|-----------|--|---|
| 0 | 0 | Output Status: Ctrl. Out 1 | 0 = OFF ; 1 = ON |
| | 1 | Output Status: Ctrl. Out 2 | 0 = OFF ; 1 = ON |
| | 2 | Output Status: Ctrl. Out 3 | 0 = OFF ; 1 = ON |
| | 3 | Output Status: Ctrl. Out 4 | 0 = OFF ; 1 = ON |
| | 4 | Output Status: Rel. 1 | 0 = OFF ; 1 = ON |
| | 5 | Output Status: Rel. 2 | 0 = OFF ; 1 = ON |
| | 6 | Output Status: Reserve | - |
| | 7 | Output Status: Reserve | - |
| 1 | 8...15 | Device status | 0 = Device is operating properly; 2 = Out-of-Specification |
| 2 | 16...23 | Scale unit Linkage Totalization | See chapter 2.9-Scale units! |
| 3...6 | 24...55 | Process value: Linkage Totalisation (incl. Dezimalpunkt u. Vorzeichen) | - |
| 7 | 56...63 | Scale unit: Totalization Input 2 | See chapter 2.9-Scale units!! |
| 8...11 | 64...95 | Process value: Totalization Input 2 (incl. Dezimalpunkt u. Vorzeichen) | - |
| 12 | 96...103 | Scale unit: Totalisation Input 1 | See chapter 2.9-Scale units!! |
| 13...16 | 104...135 | Process value: Totalization Input 1 (incl. decimal point and sign) | - |
| 17 | 136...143 | Scale unit: Linkage Input 1+2 | See chapter 2.9-Scale units! |
| 18...21 | 144...175 | Process value: Linkage Input 1+2 | - |

| | | | |
|---------|-----------|--|------------------------------|
| | | (incl. decimal point and sign) | |
| 22 | 176...183 | Scale unit: Input 2 | See chapter 2.9-Scale units! |
| 23...26 | 184...215 | Process value: Input 2 (incl. decimal point and sign) | - |
| 27 | 216...223 | Scale unit:: Input 1 | See chapter 2.9-Scale units! |
| 28...31 | 224...255 | Process value: Input 1 (incl. decimal point and sign) | - |

6.3.6.2 Process output data (8 Byte)

View from the IO-link master!

| Byte | Bit | Function | Logic |
|-------|---------|---|-------|
| 0...3 | 0...31 | IO-Link display value 1 (Data type: long - incl. sign) | - |
| 4...7 | 32...63 | IO-Link display value 2 (Data type: long - incl. sign) | - |

6.3.6.3 Assignment table of the transferred unit

| Transferred value (decimal) | Appropriate scale unit | Related code „IODD StandardUnitDefinitions1.1“ |
|-----------------------------|------------------------|--|
| 0 | V | 1240 |
| 1 | mV | 1243 |
| 2 | A | 1209 |
| 3 | mA | 1211 |
| 4 | km/h | 1064 |
| 5 | mph | 1065 |
| 6 | feet/min | 1070 |
| 7 | inch/min | 1069 |
| 8 | g | 1089 |
| 9 | kg | 1088 |
| 10 | oz | 1569 |
| 11 | W | 1186 |
| 12 | kW | 1190 |
| 13 | VA | - |
| 14 | mm | 1013 |
| 15 | cm | 1012 |
| 16 | m | 1010 |
| 17 | inch | 1019 |
| 18 | feet | 1018 |
| 19 | C | 1001 |
| 20 | F | 1002 |
| 21 | K | 1000 |
| 22 | 1/sec | 1351 |

| | | |
|----|-------------------------------|------|
| 23 | 1/min | 1352 |
| 24 | 1/h | 1353 |
| 25 | gal/min | 1363 |
| 26 | Pa | 1130 |
| 27 | kPa | 1133 |
| 28 | % | 1342 |
| 29 | Edit Unit (user defined unit) | - |

6.3.7 Error type

| Error code | Name | Description |
|----------------|--|---|
| 32768 / 0x8000 | Application errors in the device-no details | Access was denied by the device. No detailed information is available. |
| 32785 / 0x8011 | Index does not exist | Access to a non-existent index. |
| 32786 / 0x8012 | Subindex does not exist | Access to a non-existent subindex.. |
| 32800 / 0x8020 | Service not available at this time | The parameter cannot be accessed at this moment. The device does not allow this in the current state. |
| 32803 / 0x8023 | Access denied | Write access to a read-only parameter. |
| 32816 / 0x8030 | Parameter value out of range | Parameter value is outside the allowed range of values. |
| 32817 / 0x8031 | Parameter value greater than specified range | The written parameter value is greater than the specified value range. |
| 32818 / 0x8032 | Parameter value less than specified range | The written parameter value is smaller than the specified value range. |
| 32819 / 0x8033 | Parameter length too large | Parameter length is greater than allowed. |
| 32820 / 0x8034 | Parameter length too small | Parameter length is less than allowed. |
| 32821 / 0x8035 | Function not available | The device does not support the command. |
| 32822 / 0x8036 | Function not available at this time | The command is not supported by the device in its current state. |
| 32832 / 0x8040 | Invalid parameter set | Written single parameter value collides with the other parameter settings. |
| 32833 / 0x8041 | Inconsistent parameter set | Inconsistencies were detected at the end of the block parameter transfer. The device plausibility check failed. |
| 32898 / 0x8082 | Application not ready | Access was denied because the device is not ready. |

6.3.8 Declaration of Conformity IO-Link module

6.4 Display of scale units

SCALE UNITS

This parameter defines the required engineering unit. This parameter does not affect the calculation of the display value. The number of decimal places must be defined with the parameter DECIMAL POINT.

| | | | | | | | | | | | | | | | | | | | | | | | | | | | | | | | | | | | | | | | | | | | | | | | | | | | | | | | | | | | | | | | | | | | | | | | | | | |
|-----------|------------------|---|---|----|---|---|----|---|---|---|---|---|---|---|---|---|---|---|---|---|---|---|---|---|---|---|---|---|---|---|---|---|---|---|---|---|---|---|---|---|---|---|---|---|---|---|---|---|---|---|---|---|---|---|---|---|---|---|---|---|---|---|---|---|---|---|---|---|---|---|---|---|---|---|
| 0 | V | Default | | | | | | | | | | | | | | | | | | | | | | | | | | | | | | | | | | | | | | | | | | | | | | | | | | | | | | | | | | | | | | | | | | | | | | | | |
| 1 | mV | | | | | | | | | | | | | | | | | | | | | | | | | | | | | | | | | | | | | | | | | | | | | | | | | | | | | | | | | | | | | | | | | | | | | | | | | |
| 2 | A | | | | | | | | | | | | | | | | | | | | | | | | | | | | | | | | | | | | | | | | | | | | | | | | | | | | | | | | | | | | | | | | | | | | | | | | | |
| 3 | mA | | | | | | | | | | | | | | | | | | | | | | | | | | | | | | | | | | | | | | | | | | | | | | | | | | | | | | | | | | | | | | | | | | | | | | | | | |
| 4 | km/h | | | | | | | | | | | | | | | | | | | | | | | | | | | | | | | | | | | | | | | | | | | | | | | | | | | | | | | | | | | | | | | | | | | | | | | | | |
| 5 | mph | | | | | | | | | | | | | | | | | | | | | | | | | | | | | | | | | | | | | | | | | | | | | | | | | | | | | | | | | | | | | | | | | | | | | | | | | |
| 6 | feet/min | | | | | | | | | | | | | | | | | | | | | | | | | | | | | | | | | | | | | | | | | | | | | | | | | | | | | | | | | | | | | | | | | | | | | | | | | |
| 7 | inch/min | | | | | | | | | | | | | | | | | | | | | | | | | | | | | | | | | | | | | | | | | | | | | | | | | | | | | | | | | | | | | | | | | | | | | | | | | |
| 8 | g | | | | | | | | | | | | | | | | | | | | | | | | | | | | | | | | | | | | | | | | | | | | | | | | | | | | | | | | | | | | | | | | | | | | | | | | | |
| 9 | kg | | | | | | | | | | | | | | | | | | | | | | | | | | | | | | | | | | | | | | | | | | | | | | | | | | | | | | | | | | | | | | | | | | | | | | | | | |
| 10 | oz | | | | | | | | | | | | | | | | | | | | | | | | | | | | | | | | | | | | | | | | | | | | | | | | | | | | | | | | | | | | | | | | | | | | | | | | | |
| 11 | W | | | | | | | | | | | | | | | | | | | | | | | | | | | | | | | | | | | | | | | | | | | | | | | | | | | | | | | | | | | | | | | | | | | | | | | | | |
| 12 | kW | | | | | | | | | | | | | | | | | | | | | | | | | | | | | | | | | | | | | | | | | | | | | | | | | | | | | | | | | | | | | | | | | | | | | | | | | |
| 13 | VA | | | | | | | | | | | | | | | | | | | | | | | | | | | | | | | | | | | | | | | | | | | | | | | | | | | | | | | | | | | | | | | | | | | | | | | | | |
| 14 | mm | | | | | | | | | | | | | | | | | | | | | | | | | | | | | | | | | | | | | | | | | | | | | | | | | | | | | | | | | | | | | | | | | | | | | | | | | |
| 15 | cm | | | | | | | | | | | | | | | | | | | | | | | | | | | | | | | | | | | | | | | | | | | | | | | | | | | | | | | | | | | | | | | | | | | | | | | | | |
| 16 | m | | | | | | | | | | | | | | | | | | | | | | | | | | | | | | | | | | | | | | | | | | | | | | | | | | | | | | | | | | | | | | | | | | | | | | | | | |
| 17 | inch | | | | | | | | | | | | | | | | | | | | | | | | | | | | | | | | | | | | | | | | | | | | | | | | | | | | | | | | | | | | | | | | | | | | | | | | | |
| 18 | feet | | | | | | | | | | | | | | | | | | | | | | | | | | | | | | | | | | | | | | | | | | | | | | | | | | | | | | | | | | | | | | | | | | | | | | | | | |
| 19 | C | | | | | | | | | | | | | | | | | | | | | | | | | | | | | | | | | | | | | | | | | | | | | | | | | | | | | | | | | | | | | | | | | | | | | | | | | |
| 20 | F | | | | | | | | | | | | | | | | | | | | | | | | | | | | | | | | | | | | | | | | | | | | | | | | | | | | | | | | | | | | | | | | | | | | | | | | | |
| 21 | K | | | | | | | | | | | | | | | | | | | | | | | | | | | | | | | | | | | | | | | | | | | | | | | | | | | | | | | | | | | | | | | | | | | | | | | | | |
| 22 | 1/sec | | | | | | | | | | | | | | | | | | | | | | | | | | | | | | | | | | | | | | | | | | | | | | | | | | | | | | | | | | | | | | | | | | | | | | | | | |
| 23 | 1/min | | | | | | | | | | | | | | | | | | | | | | | | | | | | | | | | | | | | | | | | | | | | | | | | | | | | | | | | | | | | | | | | | | | | | | | | | |
| 24 | 1/h | | | | | | | | | | | | | | | | | | | | | | | | | | | | | | | | | | | | | | | | | | | | | | | | | | | | | | | | | | | | | | | | | | | | | | | | | |
| 25 | gal/min | | | | | | | | | | | | | | | | | | | | | | | | | | | | | | | | | | | | | | | | | | | | | | | | | | | | | | | | | | | | | | | | | | | | | | | | | |
| 26 | Pa | | | | | | | | | | | | | | | | | | | | | | | | | | | | | | | | | | | | | | | | | | | | | | | | | | | | | | | | | | | | | | | | | | | | | | | | | |
| 27 | kPa | | | | | | | | | | | | | | | | | | | | | | | | | | | | | | | | | | | | | | | | | | | | | | | | | | | | | | | | | | | | | | | | | | | | | | | | | |
| 28 | % | | | | | | | | | | | | | | | | | | | | | | | | | | | | | | | | | | | | | | | | | | | | | | | | | | | | | | | | | | | | | | | | | | | | | | | | | |
| 29 | Edit Unit | <p>A customized unit with up to 16 digits can be edited using this parameter. Pressing the "OK" button opens the Edit Unit Menu.</p> <p>A unit can be created using the arrow keys (by pressing and holding the arrow keys the characters scroll fast).</p> <p>The "OK" button saves the Edit Unit Menu. The "C" button closes the Edit Unit Menu.</p> <table border="1"> <tbody> <tr> <td></td><td>!</td><td>"</td><td>#</td><td>\$</td><td>%</td><td>&</td><td>'</td><td>(</td><td>)</td><td>*</td><td>+</td><td>,</td><td>-</td><td>.</td><td>/</td><td>0</td><td>1</td> </tr> <tr> <td>8</td><td>9</td><td>:</td><td>;</td><td><</td><td>=</td><td>></td><td>?</td><td>@</td><td>A</td><td>B</td><td>C</td><td>D</td><td>E</td><td>F</td><td>G</td><td>H</td><td>I</td> </tr> <tr> <td>P</td><td>Q</td><td>R</td><td>S</td><td>T</td><td>U</td><td>V</td><td>W</td><td>X</td><td>Y</td><td>Z</td><td>[</td><td>\</td><td>]</td><td>^</td><td>_</td><td>`</td><td>a</td> </tr> <tr> <td>h</td><td>i</td><td>j</td><td>k</td><td>l</td><td>m</td><td>n</td><td>o</td><td>p</td><td>q</td><td>r</td><td>s</td><td>t</td><td>u</td><td>v</td><td>w</td><td>x</td><td>y</td> </tr> </tbody> </table> | | ! | " | # | \$ | % | & | ' | (|) | * | + | , | - | . | / | 0 | 1 | 8 | 9 | : | ; | < | = | > | ? | @ | A | B | C | D | E | F | G | H | I | P | Q | R | S | T | U | V | W | X | Y | Z | [| \ |] | ^ | _ | ` | a | h | i | j | k | l | m | n | o | p | q | r | s | t | u | v | w | x | y |
| | ! | " | # | \$ | % | & | ' | (|) | * | + | , | - | . | / | 0 | 1 | | | | | | | | | | | | | | | | | | | | | | | | | | | | | | | | | | | | | | | | | | | | | | | | | | | | | | | | | |
| 8 | 9 | : | ; | < | = | > | ? | @ | A | B | C | D | E | F | G | H | I | | | | | | | | | | | | | | | | | | | | | | | | | | | | | | | | | | | | | | | | | | | | | | | | | | | | | | | | | |
| P | Q | R | S | T | U | V | W | X | Y | Z | [| \ |] | ^ | _ | ` | a | | | | | | | | | | | | | | | | | | | | | | | | | | | | | | | | | | | | | | | | | | | | | | | | | | | | | | | | | |
| h | i | j | k | l | m | n | o | p | q | r | s | t | u | v | w | x | y | | | | | | | | | | | | | | | | | | | | | | | | | | | | | | | | | | | | | | | | | | | | | | | | | | | | | | | | | |

6.5 Parameter / serial codes

| # | Menu | Name | Serial Code | Value | Min | Max | Default |
|----|--------------------|-------------------|-------------|-------|-----------|----------|---------|
| 0 | GENERAL MENU | OPERATIONAL MODE | 0 | 0 | 0 | 5 | 0 |
| 1 | GENERAL MENU | PIN PRESELECTION | 1 | 0 | 0 | 9999 | 0 |
| 2 | GENERAL MENU | PIN PARAMETER | 2 | 0 | 0 | 9999 | 0 |
| 3 | GENERAL MENU | BACK UP MEMORY | 3 | 0 | 0 | 1 | 0 |
| 4 | GENERAL MENU | FACTORY SETTINGS | 4 | 0 | 0 | 1 | 0 |
| 5 | GENERAL MENU | == | 5 | 0 | 0 | 0 | 0 |
| 6 | GENERAL MENU | == | 6 | 0 | 0 | 0 | 0 |
| 7 | GENERAL MENU | == | 7 | 0 | 0 | 0 | 0 |
| 8 | GENERAL MENU | == | 8 | 0 | 0 | 0 | 0 |
| 9 | IN 1 PROPERTIES | CONFIGURATION | 9 | 0 | 0 | 2 | 0 |
| 10 | IN 1 PROPERTIES | START VALUE | 10 | 0 | -99999 | 99999 | 0 |
| 11 | IN 1 PROPERTIES | END VALUE | 11 | 0 | -99999 | 99999 | 10000 |
| 12 | IN 1 PROPERTIES | DECIMAL POINT | 12 | 0 | 0 | 7 | 3 |
| 13 | IN 1 PROPERTIES | SCALE UNITS | 13 | 0 | 0 | 29 | 0 |
| 14 | IN 1 PROPERTIES | SAMPLING TIME (S) | 14 | 0 | 1 | 60000 | 10 |
| 15 | IN 1 PROPERTIES | AVERAGE FILTER | 15 | 0 | 0 | 4 | 0 |
| 16 | IN 1 PROPERTIES | OFFSET | 16 | 0 | -99999 | 99999 | 0 |
| 17 | IN 1 PROPERTIES | LINEARIZATION | 17 | 0 | 0 | 2 | 0 |
| 18 | IN 1 PROPERTIES | TOTALIZATION | 18 | 0 | 0 | 1 | 0 |
| 19 | IN 1 PROPERTIES | == | 19 | 0 | 0 | 0 | 0 |
| 20 | IN 1 PROPERTIES | == | 20 | 0 | 0 | 0 | 0 |
| 21 | IN 1 PROPERTIES | == | 21 | 0 | 0 | 0 | 0 |
| 22 | IN 1 LINEARIZATION | P1(X) | A0 | 0 | -99999999 | 99999999 | 0 |
| 23 | IN 1 LINEARIZATION | P1(Y) | A1 | 0 | -99999999 | 99999999 | 0 |
| 24 | IN 1 LINEARIZATION | P2(X) | A2 | 0 | -99999999 | 99999999 | 0 |
| 25 | IN 1 LINEARIZATION | P2(Y) | A3 | 0 | -99999999 | 99999999 | 0 |
| 26 | IN 1 LINEARIZATION | P3(X) | A4 | 0 | -99999999 | 99999999 | 0 |
| 27 | IN 1 LINEARIZATION | P3(Y) | A5 | 0 | -99999999 | 99999999 | 0 |
| 28 | IN 1 LINEARIZATION | P4(X) | A6 | 0 | -99999999 | 99999999 | 0 |
| 29 | IN 1 LINEARIZATION | P4(Y) | A7 | 0 | -99999999 | 99999999 | 0 |

| | | | | | | | |
|----|-----------------------|--------|----|---|---------------|--------------|---|
| 30 | IN 1 LINEARIZATION | P5(X) | A8 | 0 | - 99999999 | 9999999 9 | 0 |
| 31 | IN 1 LINEARIZATION | P5(Y) | A9 | 0 | - 99999999 | 9999999 9 | 0 |
| 32 | IN 1 LINEARIZATION | P6(X) | B0 | 0 | - 99999999 | 9999999 9 | 0 |
| 33 | IN 1 LINEARIZATION | P6(Y) | B1 | 0 | - 99999999 | 9999999 9 | 0 |
| 34 | IN 1 LINEARIZATION | P7(X) | B2 | 0 | - 99999999 | 9999999 9 | 0 |
| 35 | IN 1 LINEARIZATION | P7(Y) | B3 | 0 | - 99999999 | 9999999 9 | 0 |
| 36 | IN 1 LINEARIZATION | P8(X) | B4 | 0 | - 99999999 | 9999999 9 | 0 |
| 37 | IN 1 LINEARIZATION | P8(Y) | B5 | 0 | - 99999999 | 9999999 9 | 0 |
| 38 | IN 1 LINEARIZATION | P9(X) | B6 | 0 | - 99999999 | 9999999 9 | 0 |
| 39 | IN 1 LINEARIZATION | P9(Y) | B7 | 0 | - 99999999 | 9999999 9 | 0 |
| 40 | IN 1 LINEARIZATION | P10(X) | B8 | 0 | - 99999999 | 9999999 9 | 0 |
| 41 | IN 1 LINEARIZATION | P10(Y) | B9 | 0 | - 99999999 | 9999999 9 | 0 |
| 42 | IN 1 LINEARIZATION | P11(X) | C0 | 0 | - 99999999 | 9999999 9 | 0 |
| 43 | IN 1 LINEARIZATION | P11(Y) | C1 | 0 | - 99999999 | 9999999 9 | 0 |
| 44 | IN 1 LINEARIZATION | P12(X) | C2 | 0 | - 99999999 | 9999999 9 | 0 |
| 45 | IN 1 LINEARIZATION | P12(Y) | C3 | 0 | - 99999999 | 9999999 9 | 0 |

| # | Menu | Name | Serial Code | Value | Min | Max | Default |
|----|-----------------------|--------|-------------|-------|---------------|--------------|---------|
| 46 | IN 1 LINEARIZATION | P13(X) | C4 | 0 | - 99999999 | 9999999 9 | 0 |
| 47 | IN 1 LINEARIZATION | P13(Y) | C5 | 0 | - 99999999 | 9999999 9 | 0 |
| 48 | IN 1 LINEARIZATION | P14(X) | C6 | 0 | - 99999999 | 9999999 9 | 0 |
| 49 | IN 1 LINEARIZATION | P14(Y) | C7 | 0 | - 99999999 | 9999999 9 | 0 |
| 50 | IN 1 LINEARIZATION | P15(X) | C8 | 0 | - 99999999 | 9999999 9 | 0 |
| 51 | IN 1 LINEARIZATION | P15(Y) | C9 | 0 | - 99999999 | 9999999 9 | 0 |
| 52 | IN 1 LINEARIZATION | P16(X) | D0 | 0 | - 99999999 | 9999999 9 | 0 |
| 53 | IN 1 LINEARIZATION | P16(Y) | D1 | 0 | - 99999999 | 9999999 9 | 0 |
| 54 | IN 1 LINEARIZATION | P17(X) | D2 | 0 | - 99999999 | 9999999 9 | 0 |
| 55 | IN 1 LINEARIZATION | P17(Y) | D3 | 0 | - 99999999 | 9999999 9 | 0 |
| 56 | IN 1 LINEARIZATION | P18(X) | D4 | 0 | - 99999999 | 9999999 9 | 0 |
| 57 | IN 1 LINEARIZATION | P18(Y) | D5 | 0 | - 99999999 | 9999999 9 | 0 |
| 58 | IN 1 LINEARIZATION | P19(X) | D6 | 0 | - 99999999 | 9999999 9 | 0 |
| 59 | IN 1 LINEARIZATION | P19(Y) | D7 | 0 | - 99999999 | 9999999 9 | 0 |
| 60 | IN 1 LINEARIZATION | P20(X) | D8 | 0 | - 99999999 | 9999999 9 | 0 |
| 61 | IN 1 LINEARIZATION | P20(Y) | D9 | 0 | - 99999999 | 9999999 9 | 0 |
| 62 | IN 1 LINEARIZATION | P21(X) | E0 | 0 | - 99999999 | 9999999 9 | 0 |
| 63 | IN 1 LINEARIZATION | P21(Y) | E1 | 0 | - 99999999 | 9999999 9 | 0 |
| 64 | IN 1 LINEARIZATION | P22(X) | E2 | 0 | - 99999999 | 9999999 9 | 0 |
| 65 | IN 1 LINEARIZATION | P22(Y) | E3 | 0 | - 99999999 | 9999999 9 | 0 |
| 66 | IN 1 LINEARIZATION | P23(X) | E4 | 0 | - 99999999 | 9999999 9 | 0 |
| 67 | IN 1 LINEARIZATION | P23(Y) | E5 | 0 | - 99999999 | 9999999 9 | 0 |
| 68 | IN 1 LINEARIZATION | P24(X) | E6 | 0 | - 99999999 | 9999999 9 | 0 |
| 69 | IN 1 | P24(Y) | E7 | 0 | - | 9999999 | 0 |

| | | | | | | | |
|----|-------------------|-------------------|----|---|----------|-------|-------|
| | LINEARIZATION | | | | 99999999 | 9 | |
| 70 | IN 1 TOTALIZATION | BASE | E8 | 0 | 0 | 3 | 0 |
| 71 | IN 1 TOTALIZATION | DIVIDER | E9 | 0 | 0 | 3 | 0 |
| 72 | IN 1 TOTALIZATION | DECIMAL POINT | F0 | 0 | 0 | 7 | 0 |
| 73 | IN 1 TOTALIZATION | SCALE UNITS | F1 | 0 | 0 | 29 | 0 |
| 74 | IN 1 TOTALIZATION | __ | F2 | 0 | 0 | 0 | 0 |
| 75 | IN 1 TOTALIZATION | __ | F3 | 0 | 0 | 0 | 0 |
| 76 | IN 1 TOTALIZATION | __ | F4 | 0 | 0 | 0 | 0 |
| 77 | IN 2 PROPERTIES | CONFIGURATI ON | F5 | 0 | 0 | 2 | 0 |
| 78 | IN 2 PROPERTIES | START VALUE | F6 | 0 | -99999 | 99999 | 0 |
| 79 | IN 2 PROPERTIES | END VALUE | F7 | 0 | -99999 | 99999 | 10000 |
| 80 | IN 2 PROPERTIES | DECIMAL POINT | F8 | 0 | 0 | 7 | 3 |
| 81 | IN 2 PROPERTIES | SCALE UNITS | F9 | 0 | 0 | 29 | 0 |
| 82 | IN 2 PROPERTIES | SAMPLING TIME (S) | G0 | 0 | 1 | 60000 | 10 |
| 83 | IN 2 PROPERTIES | AVERAGE FILTER | G1 | 0 | 0 | 4 | 0 |
| 84 | IN 2 PROPERTIES | OFFSET | G2 | 0 | -99999 | 99999 | 0 |
| 85 | IN 2 PROPERTIES | LINEARIZATIO N | G3 | 0 | 0 | 2 | 0 |
| 86 | IN 2 PROPERTIES | TOTALIZATIO N | G4 | 0 | 0 | 1 | 0 |
| 87 | IN 2 PROPERTIES | __ | G5 | 0 | 0 | 0 | 0 |
| 88 | IN 2 PROPERTIES | __ | G6 | 0 | 0 | 0 | 0 |
| 89 | IN 2 PROPERTIES | __ | G7 | 0 | 0 | 0 | 0 |

| # | Menue | Name | Serial Code | Value | Min | Max | Default |
|-----|--------------------|--------|-------------|-------|---------------|--------------|---------|
| 90 | IN 2 LINEARIZATION | P1(X) | G8 | 0 | - 99999999 | 9999999 9 | 0 |
| 91 | IN 2 LINEARIZATION | P1(Y) | G9 | 0 | - 99999999 | 9999999 9 | 0 |
| 92 | IN 2 LINEARIZATION | P2(X) | H0 | 0 | - 99999999 | 9999999 9 | 0 |
| 93 | IN 2 LINEARIZATION | P2(Y) | H1 | 0 | - 99999999 | 9999999 9 | 0 |
| 94 | IN 2 LINEARIZATION | P3(X) | H2 | 0 | - 99999999 | 9999999 9 | 0 |
| 95 | IN 2 LINEARIZATION | P3(Y) | H3 | 0 | - 99999999 | 9999999 9 | 0 |
| 96 | IN 2 LINEARIZATION | P4(X) | H4 | 0 | - 99999999 | 9999999 9 | 0 |
| 97 | IN 2 LINEARIZATION | P4(Y) | H5 | 0 | - 99999999 | 9999999 9 | 0 |
| 98 | IN 2 LINEARIZATION | P5(X) | H6 | 0 | - 99999999 | 9999999 9 | 0 |
| 99 | IN 2 LINEARIZATION | P5(Y) | H7 | 0 | - 99999999 | 9999999 9 | 0 |
| 100 | IN 2 LINEARIZATION | P6(X) | H8 | 0 | - 99999999 | 9999999 9 | 0 |
| 101 | IN 2 LINEARIZATION | P6(Y) | H9 | 0 | - 99999999 | 9999999 9 | 0 |
| 102 | IN 2 LINEARIZATION | P7(X) | I0 | 0 | - 99999999 | 9999999 9 | 0 |
| 103 | IN 2 LINEARIZATION | P7(Y) | I1 | 0 | - 99999999 | 9999999 9 | 0 |
| 104 | IN 2 LINEARIZATION | P8(X) | I2 | 0 | - 99999999 | 9999999 9 | 0 |
| 105 | IN 2 LINEARIZATION | P8(Y) | I3 | 0 | - 99999999 | 9999999 9 | 0 |
| 106 | IN 2 LINEARIZATION | P9(X) | I4 | 0 | - 99999999 | 9999999 9 | 0 |
| 107 | IN 2 LINEARIZATION | P9(Y) | I5 | 0 | - 99999999 | 9999999 9 | 0 |
| 108 | IN 2 LINEARIZATION | P10(X) | I6 | 0 | - 99999999 | 9999999 9 | 0 |
| 109 | IN 2 LINEARIZATION | P10(Y) | I7 | 0 | - 99999999 | 9999999 9 | 0 |
| 110 | IN 2 LINEARIZATION | P11(X) | I8 | 0 | - 99999999 | 9999999 9 | 0 |
| 111 | IN 2 LINEARIZATION | P11(Y) | I9 | 0 | - 99999999 | 9999999 9 | 0 |
| 112 | IN 2 LINEARIZATION | P12(X) | J0 | 0 | - 99999999 | 9999999 9 | 0 |
| 113 | IN 2 LINEARIZATION | P12(Y) | J1 | 0 | - 99999999 | 9999999 9 | 0 |
| 114 | IN 2 LINEARIZATION | P13(X) | J2 | 0 | - | 9999999 | 0 |

| | | | | | | | |
|-----|--------------------|--------|----|---|---------------|--------------|---|
| | | | | | 99999999 | 9 | |
| 115 | IN 2 LINEARIZATION | P13(Y) | J3 | 0 | - 99999999 | 9999999 9 | 0 |
| 116 | IN 2 LINEARIZATION | P14(X) | J4 | 0 | - 99999999 | 9999999 9 | 0 |
| 117 | IN 2 LINEARIZATION | P14(Y) | J5 | 0 | - 99999999 | 9999999 9 | 0 |
| 118 | IN 2 LINEARIZATION | P15(X) | J6 | 0 | - 99999999 | 9999999 9 | 0 |
| 119 | IN 2 LINEARIZATION | P15(Y) | J7 | 0 | - 99999999 | 9999999 9 | 0 |
| 120 | IN 2 LINEARIZATION | P16(X) | J8 | 0 | - 99999999 | 9999999 9 | 0 |
| 121 | IN 2 LINEARIZATION | P16(Y) | J9 | 0 | - 99999999 | 9999999 9 | 0 |
| 122 | IN 2 LINEARIZATION | P17(X) | K0 | 0 | - 99999999 | 9999999 9 | 0 |
| 123 | IN 2 LINEARIZATION | P17(Y) | K1 | 0 | - 99999999 | 9999999 9 | 0 |
| 124 | IN 2 LINEARIZATION | P18(X) | K2 | 0 | - 99999999 | 9999999 9 | 0 |
| 125 | IN 2 LINEARIZATION | P18(Y) | K3 | 0 | - 99999999 | 9999999 9 | 0 |
| 126 | IN 2 LINEARIZATION | P19(X) | K4 | 0 | - 99999999 | 9999999 9 | 0 |
| 127 | IN 2 LINEARIZATION | P19(Y) | K5 | 0 | - 99999999 | 9999999 9 | 0 |
| 128 | IN 2 LINEARIZATION | P20(X) | K6 | 0 | - 99999999 | 9999999 9 | 0 |
| 129 | IN 2 LINEARIZATION | P20(Y) | K7 | 0 | - 99999999 | 9999999 9 | 0 |
| 130 | IN 2 LINEARIZATION | P21(X) | K8 | 0 | - 99999999 | 9999999 9 | 0 |
| 131 | IN 2 LINEARIZATION | P21(Y) | K9 | 0 | - 99999999 | 9999999 9 | 0 |
| 132 | IN 2 LINEARIZATION | P22(X) | L0 | 0 | - 99999999 | 9999999 9 | 0 |
| 133 | IN 2 LINEARIZATION | P22(Y) | L1 | 0 | - 99999999 | 9999999 9 | 0 |
| 134 | IN 2 LINEARIZATION | P23(X) | L2 | 0 | - 99999999 | 9999999 9 | 0 |
| 135 | IN 2 LINEARIZATION | P23(Y) | L3 | 0 | - 99999999 | 9999999 9 | 0 |
| 136 | IN 2 LINEARIZATION | P24(X) | L4 | 0 | - 99999999 | 9999999 9 | 0 |
| 137 | IN 2 LINEARIZATION | P24(Y) | L5 | 0 | - 99999999 | 9999999 9 | 0 |

Continuation „Parameter“

| # | Menue | Name | Serial Code | Value | Min | Max | Default |
|-----|---------------------|--------------------|-------------|-------|---------------|--------------|---------|
| 138 | IN 2 TOTALIZATION | BASE | L6 | 0 | 0 | 3 | 0 |
| 139 | IN 2 TOTALIZATION | DIVIDER | L7 | 0 | 0 | 3 | 0 |
| 140 | IN 2 TOTALIZATION | DECIMAL POINT | L8 | 0 | 0 | 7 | 0 |
| 141 | IN 2 TOTALIZATION | SCALE UNITS | L9 | 0 | 0 | 29 | 0 |
| 142 | IN 2 TOTALIZATION | — | M0 | 0 | 0 | 0 | 0 |
| 143 | IN 2 TOTALIZATION | — | M1 | 0 | 0 | 0 | 0 |
| 144 | IN 2 TOTALIZATION | — | M2 | 0 | 0 | 0 | 0 |
| 145 | LINKAGE PROPERTIES | FACTOR | M3 | 0 | - 99999999 | 9999999 9 | 1 |
| 146 | LINKAGE PROPERTIES | DIVIDER | M4 | 0 | - 99999999 | 9999999 9 | 1 |
| 147 | LINKAGE PROPERTIES | ADDITIVE VALUE | M5 | 0 | - 99999999 | 9999999 9 | 0 |
| 148 | LINKAGE PROPERTIES | DECIMAL POINT | M6 | 0 | 0 | 7 | 0 |
| 149 | LINKAGE PROPERTIES | SCALE UNITS | M7 | 0 | 0 | 29 | 0 |
| 150 | LINKAGE PROPERTIES | — | M8 | 0 | 0 | 0 | 0 |
| 151 | LINKAGE PROPERTIES | — | M9 | 0 | 0 | 0 | 0 |
| 152 | LINKAGE PROPERTIES | — | N0 | 0 | 0 | 0 | 0 |
| 153 | IO LINK PROPERTIES | IN1 FACTOR | N1 | 0 | - 99999999 | 9999999 9 | 1 |
| 154 | IO LINK PROPERTIES | IN1 DEVIDER | N2 | 0 | - 99999999 | 9999999 9 | 1 |
| 155 | IO LINK PROPERTIES | IN1 ADDITIVE VALUE | N3 | 0 | - 99999999 | 9999999 9 | 0 |
| 156 | IO LINK PROPERTIES | IN1 DECIMAL POINT | N4 | 0 | 0 | 7 | 0 |
| 157 | IO LINK PROPERTIES | IN1 SCALE UNITS | N5 | 0 | 0 | 29 | 0 |
| 158 | IO LINK PROPERTIES | IN2 FACTOR | N6 | 0 | - 99999999 | 9999999 9 | 1 |
| 159 | IO LINK PROPERTIES | IN2 DEVIDER | N7 | 0 | - 99999999 | 9999999 9 | 1 |
| 160 | IO LINK PROPERTIES | IN2 ADDITIVE VALUE | N8 | 0 | - 99999999 | 9999999 9 | 0 |
| 161 | IO LINK PROPERTIES | IN2 DECIMAL POINT | N9 | 0 | 0 | 7 | 0 |
| 162 | IO LINK PROPERTIES | IN2 SCALE UNITS | O0 | 0 | 0 | 29 | 0 |
| 163 | IO LINK PROPERTIES | — | O1 | 0 | 0 | 0 | 0 |
| 164 | IO LINK PROPERTIES | — | O2 | 0 | 0 | 0 | 0 |
| 165 | IO LINK PROPERTIES | — | O3 | 0 | 0 | 0 | 0 |
| 166 | IO LINK PROPERTIES | — | O4 | 0 | 0 | 0 | 0 |
| 167 | PRESELECTION VALUES | PRESELECTION 1 | O5 | 0 | - 99999999 | 9999999 9 | 1000 |

| | | | | | | | |
|-----|---------------------|-------------------|----|---|---------------|--------------|------|
| 168 | PRESELECTION VALUES | PRESELECTION 2 | O6 | 0 | - 99999999 | 9999999 9 | 2000 |
| 169 | PRESELECTION VALUES | PRESELECTION 3 | O7 | 0 | - 99999999 | 9999999 9 | 3000 |
| 170 | PRESELECTION VALUES | PRESELECTION 4 | O8 | 0 | - 99999999 | 9999999 9 | 4000 |
| 171 | PRESELECTION VALUES | — | O9 | 0 | 0 | 0 | 0 |
| 172 | PRESELECTION VALUES | — | P0 | 0 | 0 | 0 | 0 |
| 173 | PRESELECTION 1 MENU | SOURCE 1 | P1 | 0 | 0 | 11 | 0 |
| 174 | PRESELECTION 1 MENU | MODE 1 | P2 | 0 | 0 | 6 | 0 |
| 175 | PRESELECTION 1 MENU | HYSTERESIS 1 | P3 | 0 | 0 | 99999 | 0 |
| 176 | PRESELECTION 1 MENU | PULSE TIME 1 | P4 | 0 | 0 | 60000 | 0 |
| 177 | PRESELECTION 1 MENU | OUTPUT TARGET 1 | P5 | 0 | 0 | 6 | 1 |
| 178 | PRESELECTION 1 MENU | OUTPUT POLARITY 1 | P6 | 0 | 0 | 1 | 0 |
| 179 | PRESELECTION 1 MENU | OUTPUT LOCK 1 | P7 | 0 | 0 | 1 | 0 |
| 180 | PRESELECTION 1 MENU | START UP DELAY 1 | P8 | 0 | 0 | 60000 | 0 |
| 181 | PRESELECTION 1 MENU | EVENT COLOR 1 | P9 | 0 | 0 | 3 | 0 |
| 182 | PRESELECTION 1 MENU | — | Q0 | 0 | 0 | 0 | 0 |
| 183 | PRESELECTION 1 MENU | — | Q1 | 0 | 0 | 0 | 0 |

Continuation „Parameter / serial codes“:

| # | Menue | Name | Serial Code | Value | Min | Max | Default |
|-----|---------------------|-------------------|-------------|-------|-----|-------|---------|
| 184 | PRESELECTION 2 MENU | SOURCE 2 | Q2 | 0 | 0 | 11 | 0 |
| 185 | PRESELECTION 2 MENU | MODE 2 | Q3 | 0 | 0 | 6 | 0 |
| 186 | PRESELECTION 2 MENU | HYSTERESIS 2 | Q4 | 0 | 0 | 99999 | 0 |
| 187 | PRESELECTION 2 MENU | PULSE TIME 2 | Q5 | 0 | 0 | 60000 | 0 |
| 188 | PRESELECTION 2 MENU | OUTPUT TARGET 2 | Q6 | 0 | 0 | 6 | 2 |
| 189 | PRESELECTION 2 MENU | OUTPUT POLARITY 2 | Q7 | 0 | 0 | 1 | 0 |
| 190 | PRESELECTION 2 MENU | OUTPUT LOCK 2 | Q8 | 0 | 0 | 1 | 0 |
| 191 | PRESELECTION 2 MENU | START UP DELAY 2 | Q9 | 0 | 0 | 60000 | 0 |
| 192 | PRESELECTION 2 MENU | EVENT COLOR 2 | R0 | 0 | 0 | 3 | 0 |
| 193 | PRESELECTION 2 MENU | — | R1 | 0 | 0 | 0 | 0 |
| 194 | PRESELECTION 2 MENU | — | R2 | 0 | 0 | 0 | 0 |
| 195 | PRESELECTION 3 MENU | SOURCE 3 | R3 | 0 | 0 | 11 | 0 |
| 196 | PRESELECTION 3 MENU | MODE 3 | R4 | 0 | 0 | 6 | 0 |
| 197 | PRESELECTION 3 MENU | HYSTERESIS 3 | R5 | 0 | 0 | 99999 | 0 |
| 198 | PRESELECTION 3 MENU | PULSE TIME 3 | R6 | 0 | 0 | 60000 | 0 |
| 199 | PRESELECTION 3 MENU | OUTPUT TARGET 3 | R7 | 0 | 0 | 6 | 3 |
| 200 | PRESELECTION 3 MENU | OUTPUT POLARITY 3 | R8 | 0 | 0 | 1 | 0 |
| 201 | PRESELECTION 3 MENU | OUTPUT LOCK 3 | R9 | 0 | 0 | 1 | 0 |
| 202 | PRESELECTION 3 MENU | START UP DELAY 3 | S0 | 0 | 0 | 1 | 0 |
| 203 | PRESELECTION 3 MENU | EVENT COLOR 3 | 90 | 0 | 0 | 3 | 0 |
| 204 | PRESELECTION 3 MENU | — | 91 | 0 | 0 | 0 | 0 |
| 205 | PRESELECTION 3 MENU | — | 92 | 0 | 0 | 0 | 0 |

| | | | | | | | |
|-----|---------------------|-------------------|----|---|----|-------|-----|
| 206 | PRESELECTION 4 MENU | SOURCE 4 | 9~ | 0 | 0 | 11 | 0 |
| 207 | PRESELECTION 4 MENU | MODE 4 | S1 | 0 | 0 | 6 | 0 |
| 208 | PRESELECTION 4 MENU | HYSTERESIS 4 | S2 | 0 | 0 | 99999 | 0 |
| 209 | PRESELECTION 4 MENU | PULSE TIME 4 | S3 | 0 | 0 | 60000 | 0 |
| 210 | PRESELECTION 4 MENU | OUTPUT TARGET 4 | S4 | 0 | 0 | 6 | 4 |
| 211 | PRESELECTION 4 MENU | OUTPUT POLARITY 4 | S5 | 0 | 0 | 1 | 0 |
| 212 | PRESELECTION 4 MENU | OUTPUT LOCK 4 | S6 | 0 | 0 | 1 | 0 |
| 213 | PRESELECTION 4 MENU | START UP DELAY 4 | S7 | 0 | 0 | 1 | 0 |
| 214 | PRESELECTION 4 MENU | EVENT COLOR 4 | S8 | 0 | 0 | 3 | 0 |
| 215 | PRESELECTION 4 MENU | — | S9 | 0 | 0 | 0 | 0 |
| 216 | PRESELECTION 4 MENU | — | T0 | 0 | 0 | 0 | 0 |
| 217 | SERIAL MENU | UNIT NUMBER | T1 | 0 | 11 | 99 | 11 |
| 218 | SERIAL MENU | SERIAL BAUD RATE | T2 | 0 | 0 | 2 | 0 |
| 219 | SERIAL MENU | SERIAL FORMAT | T3 | 0 | 0 | 9 | 0 |
| 220 | SERIAL MENU | SERIAL INIT | T4 | 0 | 0 | 1 | 0 |
| 221 | SERIAL MENU | SERIAL PROTOCOL | T5 | 0 | 0 | 1 | 0 |
| 222 | SERIAL MENU | SERIAL TIMER | T6 | 0 | 0 | 60000 | 0 |
| 223 | SERIAL MENU | SERIAL VALUE | T7 | 0 | 0 | 9 | 0 |
| 224 | SERIAL MENU | MODBUS | T8 | 0 | 0 | 0 | 247 |
| 225 | SERIAL MENU | — | T9 | 0 | 0 | 0 | 0 |

Continuation „Parameter / serial codes“:

| # | Menue | Name | Serial Code | Value | Min | Max | Default |
|-----|-----------------|------------------|-------------|-------|---------------|--------------|---------|
| 226 | ANALOG OUT MENU | ANALOG SOURCE | U0 | 0 | 0 | 11 | 0 |
| 227 | ANALOG OUT MENU | ANALOG FORMAT | U1 | 0 | 0 | 2 | 0 |
| 228 | ANALOG OUT MENU | ANALOG START | U2 | 0 | - 99999999 | 9999999 9 | 0 |
| 229 | ANALOG OUT MENU | ANALOG END | U3 | 0 | - 99999999 | 9999999 9 | 10000 |
| 230 | ANALOG OUT MENU | ANALOG GAIN % | U4 | 0 | 0 | 11000 | 10000 |
| 231 | ANALOG OUT MENU | ANALOG OFFSET % | U5 | 0 | -9999 | 9999 | 0 |
| 232 | ANALOG OUT MENU | — | U6 | 0 | 0 | 0 | 0 |
| 233 | ANALOG OUT MENU | — | U7 | 0 | 0 | 0 | 0 |
| 234 | COMMAND MENU | INPUT 1 ACTION | U8 | 0 | 0 | 26 | 0 |
| 235 | COMMAND MENU | INPUT 1 CONFIG. | U9 | 0 | 0 | 3 | 2 |
| 236 | COMMAND MENU | INPUT 2 ACTION | V0 | 0 | 0 | 26 | 0 |
| 237 | COMMAND MENU | INPUT 2 CONFIG. | V1 | 0 | 0 | 3 | 2 |
| 238 | COMMAND MENU | INPUT 3 ACTION | V2 | 0 | 0 | 26 | 0 |
| 239 | COMMAND MENU | INPUT 3 CONFIG. | V3 | 0 | 0 | 3 | 2 |
| 240 | COMMAND MENU | — | V4 | 0 | 0 | 0 | 0 |
| 241 | COMMAND MENU | — | V5 | 0 | 0 | 0 | 0 |
| 242 | COMMAND MENU | — | V6 | 0 | 0 | 0 | 0 |
| 243 | COMMAND MENU | — | V7 | 0 | 0 | 0 | 0 |
| 244 | DISPLAY MENU | START DISPLAY | V8 | 0 | 0 | 1 | 0 |
| 245 | DISPLAY MENU | SOURCE SINGLE | V9 | 0 | 0 | 11 | 0 |
| 246 | DISPLAY MENU | SOURCE DUAL TOP | W0 | 0 | 0 | 11 | 0 |
| 247 | DISPLAY MENU | SOURCE DUAL DOWN | W1 | 0 | 0 | 11 | 1 |
| 248 | DISPLAY MENU | LARGE DISPLAY | W2 | 0 | 0 | 6 | 0 |
| 249 | DISPLAY MENU | SOURCE LARGE | W3 | 0 | 0 | 11 | 0 |
| 250 | DISPLAY MENU | COLOR | W4 | 0 | 0 | 2 | 0 |
| 251 | DISPLAY MENU | BRIGHTNESS | W5 | 0 | 10 | 100 | 80 |
| 252 | DISPLAY MENU | CONTRAST | W6 | 0 | 0 | 2 | 1 |
| 253 | DISPLAY MENU | SCREEN SAVER | W7 | 0 | 0 | 9999 | 0 |
| 254 | DISPLAY MENU | UP-DATE-TIME | W8 | 0 | 5 | 9999 | 100 |
| 255 | DISPLAY MENU | FONT | W9 | 0 | 0 | 1 | 0 |
| 256 | DISPLAY MENU | — | a0 | 0 | 0 | 0 | 0 |

Serial codes of commands:

| Serial Code | Command |
|--------------------|----------------------|
| 54 | TARA INPUT 1 |
| 55 | TARA INPUT 2 |
| 56 | TARA INPUT 1 + 2 |
| 57 | RESET TOTAL 1 |
| 58 | RESET TOTAL 2 |
| 59 | RESET TOTAL LINKAGE |
| 60 | TEACH PRESELECTION 1 |
| 61 | TEACH PRESELECTION 2 |
| 62 | TEACH PRESELECTION 3 |
| 63 | TEACH PRESELECTION 4 |
| 64 | SCROLL DISPLAY |
| 65 | CLEAR MIN/MAX VALUES |
| 66 | CLEAR LOOP TIME |
| 67 | ACTIVATE DATA |
| 68 | STORE EEPROM |
| 69 | TESTPROGRAMM |

6.6 Linearization

The linearization function of this unit allows converting a linear input signal into a non-linear developing (or vice versa). There are 24 programmable x/y coordinates available for input 1 and input 2, which can be set in any desired distance over the full conversion range. Between two coordinates, the unit uses linear interpolation. Therefore it is advisable to use more coordinates in a range with strong curves and only a few coordinates where the curvature is less.

To specify an individual linearization curve, the parameter LINEARISAZATION MODE must be set to either 1 QUADRANT or 4 QUADRANT (see following diagram).

The parameters P1(X) to P24(X) are used to specify the coordinates on the x-axis. These are the measuring values that the unit normally would generate according to the actual input signal.

Now enter the attached values to parameter P1(Y) to P24(Y). These are the values that the unit will generate instead of the x- values, i.e. P5(Y) replaces P5(X) etc.

The X-Coordinates must use continuously increasing settings, i.e. P1(X) must have the lowest and P24(X) must have the highest setting. If the measured value is bigger than the last defined X-value, the corresponding Y-value is displayed.

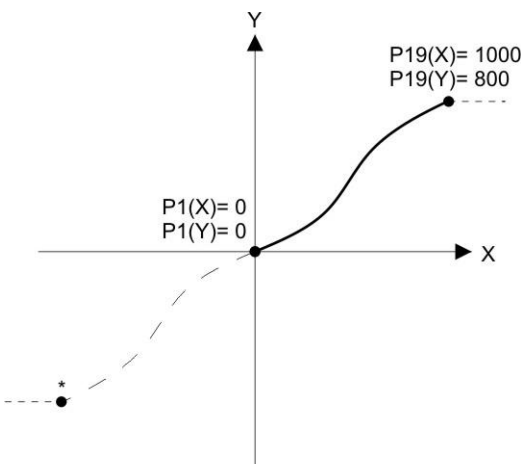

Example: Linearization Mode: 1 Quadrant

* Linearization is point symmetric to 1. Quadrant

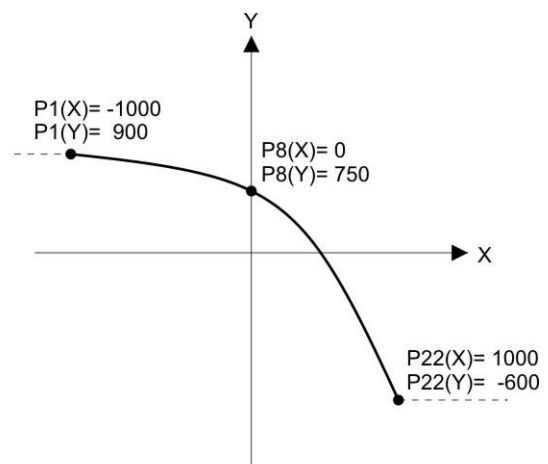

Example: Linearization Mode: 4 Quadrant

Mode: 1 Quadrant:

P1(X) must be set to zero. Linearization is only defined in the positive range and the negative range will be mirrored symmetric to central point.

Mode: 4 Quadrant:

P1(X) can also be set to a negative value. If the measured value is smaller than P1(X), P1(Y) is displayed.

Application Example:

We like to display the filling quantity (volume) of a tank as shown below, with use of a pressure sensor mounted to the bottom of the tank. With this application the analogue pressure signal is proportional to the filling level, but not to the filling quantity.

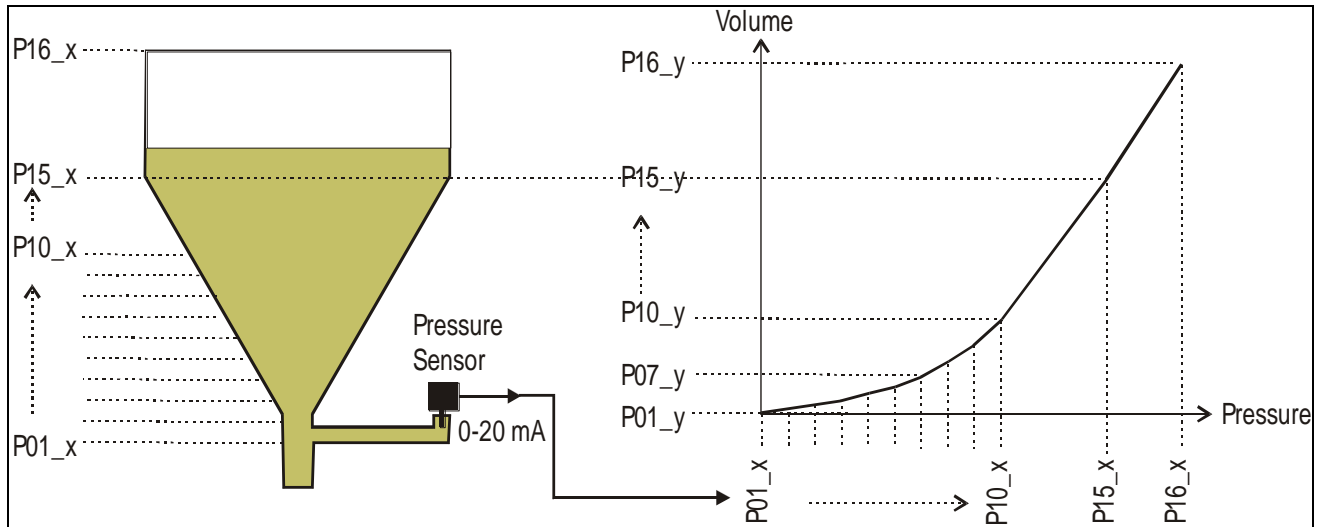

To solve the problem, we divide the non-linear part of the tank into 14 parts. We enter the expected display values of the pressure sensor to registers P01_x to P15_x. For the linear part of the tank it is sufficient to store the final pressure value to register P16_x. Now we can easily calculate the appropriate filling quantities and enter these values to the registers P01_y to P16_y.

6.7 Dimensions

Dimension in mm [inch]

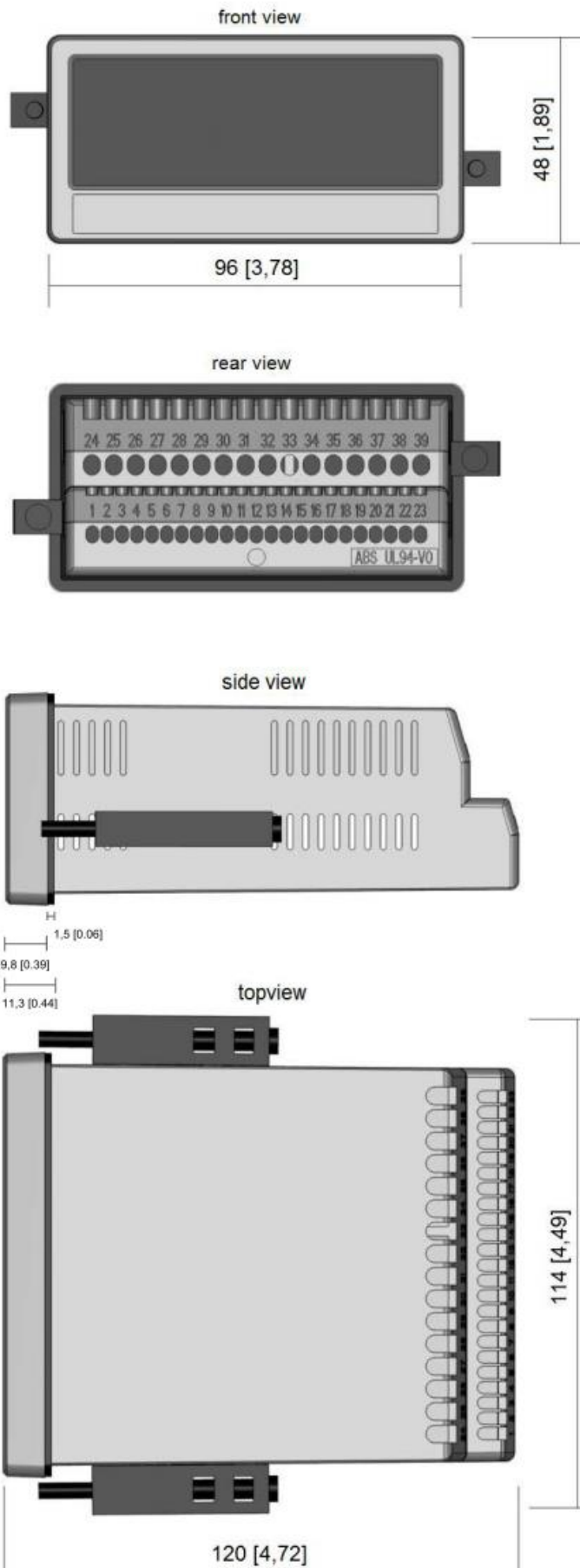

6.8 Technical specifications

| Technical Specifications: | | |
|---|-------------------------|---|
| Connections: | Connector type: | screw terminal, 1.5 mm ² / AWG 16 |
| Power supply (DC): | Input voltage: | 18 ... 30 VDC |
| | Protection circuit: | reverse polarity protection |
| | Consumption: | approx. 100 mA (unloaded) |
| | Fuse protection: | extern: T 0.5A |
| Power supply (AC): (Option) | Input voltage: | 115 ... 230 VAC, 50...60 Hz) |
| | Power consumption: | approx. 3 VA (unloaded) |
| | Fuse protection: | extern: T 0.1 A |
| Encoder supply: | DC version: | approx. 1 V lower than the power supply voltage |
| | Output current: | max. 250 mA |
| | AC version: | approx. 24 V (± 15%) |
| | Output current: | 150 mA until 45°C / 80 mA by more than 45°C |
| Reference output: | Output voltage: | 10 V |
| | Accuracy: | ± 0.1 % |
| | Load: | max. 10 mA |
| Analog inputs: | Number of inputs: | 2 |
| | Configuration: | current or voltage operation |
| | Voltage input: | -10 ... +10 V (Ri ≈ 50 kOhm) |
| | Current input: | 0 ... 20 mA / 4 ... 20 mA (Ri ≈ 100 Ohm) |
| | Resolution: | 16 bit |
| | Accuracy: | ± 0.1 % |
| Control inputs: | Number of inputs: | 3 |
| | Format: | HTL, PNP (Low 0 ... 3 V, High 9 ... 30 V) |
| | Frequency: | max. 10 kHz |
| | Load: | max. 2 mA / Ri > 15 kOhm / 470 pF |
| Analog output: (Option) | Configuration: | current or voltage operation |
| | Voltage output: | -10...+10 V (max. 2 mA) |
| | Current output: | 0/4... 20 mA (burden: max. 270 Ohm) |
| | Resolution: | 16 Bit |
| | Accuracy: | ± 0.1 % |
| | Reaction time: | < 150 ms |
| Control outputs: (Option) | Number of outputs: | 4 |
| | Format / level: | 5 ... 30 V (depends on the Com+ voltage), PNP |
| | Output current: | max. 200 mA |
| | Reaction time: | < 1 ms |
| Relay outputs: (Option) | Number of outputs: | 2 |
| | Configuration: | potential free changeovers |
| | Switching voltage: | max. 250 VAC / 3 A / 750 VA |
| | Switching current: | max. 150 VDC / 2 A / 50 W |
| | Switching power: | max. 50 W / 250 VA |
| | Reaction time: | < 20 ms |
| Serial interface: (Option RS232 or RS485) | Format: | RS232 or RS485 (see order code) |
| | Baudrate: | 9600, 19200 or 38400 baud |
| IO-Link: (Option) | Module / Revision: | Device / V1.1 |
| | Bitrate: | COM 3 |
| | Port Class: | Typ A |
| Display: | Type: | Graphic LCD with backlight |
| | Display range: | 8 decades plus sign (-99999999 ... 99999999) |
| | Digit height: | 13 mm |
| | Color: | red/ green / yellow (switchable) |
| | Operation: | resistive touchscreen |
| Housing: | Material: | ABS, UL 94 V-0 |
| | Mounting: | panel |
| | Dimensions (w x h x d): | 96 x 48 x 116 mm / 3.78 x 1.89 x 4.56 inch |
| | | 91 x 43 mm / 3.58 x 1.69 inch |

| | | |
|----------------------------------|---|---|
| | Cut out (w x h): Protection class: Weight: | IP65 (front), IP20 (rear) approx. 200 g |
| Ambient temperature: | Operation: Storage: | -20 °C ... +60 °C resp. -4 ... 140 °F -25 °C ... +70 °C resp. -13 ... 158 °F |
| Conformity and standards: | EMC 2014/30/EU: LV 2014/35/EU: RoHS 2011/65/EU: | EN 61000-6-2, EN 61000-6-3, EN 61000-6-4, EN 61326-3-2 EN 61010-1 EN 50581 |

Kübler Group
Fritz Kübler GmbH
Schubertstrasse 47
78054 Villingen-Schwenningen
Germany
Phone +49 7720 3903-0
Fax +49 7720 21564
info@kuebler.com
www.kuebler.com