

Incremental encoders

Large hollow shaft robust, optical	A02H (hollow shaft)	Push-pull / RS422 / SinCos
-----------------------------------------------	----------------------------	-----------------------------------



The Heavy Duty incremental encoder type A02H boasts a high degree of ruggedness in a very compact design.

Its special construction makes it perfect for all applications in very harsh environments.



High rotational speed



High protection level



High shaft load capacity



Shock / vibration resistant



Magnetic field proof



Optical sensor

Heavy Duty - robust

- Special shaft connection with interlocked bearings.
- Balanced stainless steel clamping ring.
- Optional isolation inserts available to protect against shaft currents.

Compact and versatile

- Only 49 mm installation depth.
- With cable connections, M12, M23 or MIL connectors.
- With push-pull, RS422 or SinCos interface.

Order code Hollow shaft

8.A02H.XXXX
Type a b c d e

a Flange

- 1 = without mounting aid
 - 2 = with spring element, short
 - 3 = with spring element, long
 - 5 = with torque stop, long
-
- 6 = with torque stop, short, 4.5" ¹⁾

b Through hollow shaft

- C = ø 20 mm [0.79"]
- 5 = ø 25 mm [0.98"]
- 3 = ø 28 mm [1.10"]
- A = ø 30 mm [1.18"]
- 2 = ø 38 mm [1.50"]
- B = ø 40 mm [1.57"]
- 1 = ø 42 mm [1.65"]
- 4 = ø 1"

- E = ø 5/8" ¹⁾
- N = ø 1 1/4" ¹⁾

c Output circuit / power supply

- 1 = RS422 (with inverted signal) / 5 V DC
 - 4 = RS422 (with inverted signal) / 10 ... 30 V DC
 - 2 = Push-pull (without inverted signal) / 10 ... 30 V DC
 - 5 = Push-pull (with inverted signal) / 5 ... 30 V DC
 - 3 = Push-pull (with inverted signal) / 10 ... 30 V DC
 - 8 = SinCos, 1 Vpp (with inverted signal) / 5 V DC
 - 9 = SinCos, 1 Vpp (with inverted signal) / 10 ... 30 V DC
 - A = Push-pull (7272 compatible) / 5 ... 30 V DC
-
- D = RS422 (with inverted signal) / 5 ... 30 V DC ¹⁾

d Type of connection

- 1 = radial cable, 1 m [3.28'] PVC
- A = radial cable, special length PVC *)
- 2 = radial M23 connector, 12-pin, without mating connector
- E = radial M12 connector, 8-pin

D = MIL connector, 10-pin ¹⁾

*) Available special lengths (connection type A):
2, 3, 5, 8, 10, 15 m [6.56, 9.84, 16.40, 26.25, 32.80, 49.21']
order code expansion .XXXX = length in dm
ex.: 8.A02H.111A.2048.0030 (for cable length 3 m)

e Pulse rate

- 50, 360, 512, 600, 1000, 1024, 1500, 2000, 2048, 2500, 4096, 5000 (e.g. 360 pulses => 0360)

SinCos version only available with pulses ≥ 1024

Optional on request

- other pulse rates on request
- Ex 2/22 ²⁾

1) US version.

2) For the cable connection type, cable material PUR.

Incremental encoders

Large hollow shaft robust, optical	A02H (hollow shaft)	Push-pull / RS422 / SinCos
-----------------------------------------------	----------------------------	-----------------------------------

Mounting accessory for hollow shaft encoders	Dimensions in mm [inch]	Order no.
----------------------------------------------	-------------------------	-----------

Cylindrical pin, long
for flange with spring element
(flange type 2 + 3)

with fixing thread

8.0010.4700.0003

Tether arm, flexible

Tether arm	L1	L2
70 mm [2.76"]	64 ... 74 [2.51 ... 2.91]	82 ... 92 [3.23 ... 3.62]
100 mm [3.94"]	94 ... 104 [3.70 ... 4.09]	112 ... 122 [4.41 ... 4.80]
150 mm [5.91"]	144 ... 154 [5.67 ... 6.06]	162 ... 172 [6.38 ... 6.77]

70 mm [2.76"]
100 mm [3.94"]
150 mm [5.91"]

8.0010.40S0.0000
8.0010.40T0.0000
8.0010.40U0.0000

- 1 Socket screw M2.5 x 6 [0.24]
- 2 Lock washer

Torque stop, short



8.0010.4T00.0000

- 1 Curved spring element
- 2 Hexagonal nut 3/8 - 16 UNC
- 3 Washer (isolating)
- 4 Hexagonal screw 3/8 16 UNC x 1"
- 5 Washer D10.4 x 15 x 15

Stator coupling

8.0010.40V0.0000

Incremental encoders

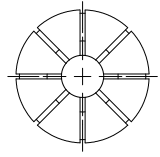
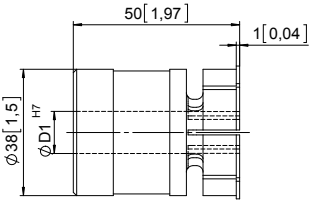
Large hollow shaft robust, optical		A02H (hollow shaft)	Push-pull / RS422 / SinCos
Mounting accessory for hollow shaft encoders			Order no.
Protective cover 	For applications with a very high degree of pollution, Kübler now offers a protective cover for <ul style="list-style-type: none"> Improved reliability Extension of the service life of the encoder Scope of delivery: <ul style="list-style-type: none"> Protective cover Torque stop (8.0010.4T00.0000) 3 screws for fixing to the encoder 		8.0010.40Y0.0001
Tapered shaft mounting kit for A02H with hollow shaft, \varnothing 38 mm [1.50"] 	For use in upgrading for tapered shaft mounting. Tapered shafts are used for high-precision direct coupling. An isolation insert is also included in the mounting kit; this reliably protects the encoder from shaft currents. Included in the set: <ul style="list-style-type: none"> Insert for cone blind hole, cone 1:10, 17 mm [0.67"] length Isolation insert Allen screw for central fixing 		8.0010.4028.0000
Isolation insert for hollow shaft, \varnothing 38 mm [1.50"] Temperature range -40°C ... +115°C [-40°F ... +239°F]   	Isolation inserts prevent currents from passing through the encoder bearings. These currents can occur when using inverter controlled three-phase or AC vector motors and considerably shorten the service life of the encoder bearings. For more details please call our technical hotline (+49 7720 3903 952) or send us an email (info@kuebler.com)	\varnothing D1: 12 mm [0.47"] 14 mm [0.55"] 15 mm [0.59"] 16 mm [0.63"] 18 mm [0.71"] 20 mm [0.79"] 25 mm [0.98"] 30 mm [1.18"] 32 mm [1.26"] 1/2" 5/8" 3/4" 1" 1 1/4"	8.0010.4091.0000 8.0010.4027.0000 8.0010.4038.0000 8.0010.4019.0000 8.0010.4080.0000 8.0010.4011.0000 8.0010.4012.0000 8.0010.4016.0000 8.0010.4015.0000 8.0010.4013.0000 8.0010.4070.0000 8.0010.4090.0000 8.0010.4050.0000 8.0010.4060.0000
Isolation insert for hollow shaft, \varnothing 42 mm [1.65"]	external diameter 42 mm [1.65"] / internal diameter 38 mm [1.50"] external diameter 42 mm [1.65"] / internal diameter 12 mm [0.47"]		8.0010.4017.0000 8.0010.4029.0000
Connection technology			Order no.
Cordset, pre-assembled	M12 female connector with coupling nut, 8-pin 2 m [6.56'] PVC cable M23 female connector with coupling nut, 12-pin 2 m [6.56'] PVC cable		05.00.6041.8211.002M 8.0000.6201.0002
Connector, self-assembly (straight)	M12 female connector with coupling nut, 8-pin M23 female connector with coupling nut, 12-pin		05.CMB 8181-0 8.0000.5012.0000

Further accessories can be found in the accessories section or in the accessories area of our website at: www.kuebler.com/accessories.
 Additional connectors can be found in the connection technology section or in the connection technology area of our website at: www.kuebler.com/connection_technology.

Incremental encoders

Large hollow shaft robust, optical	A02H (hollow shaft)	Push-pull / RS422 / SinCos
-----------------------------------------------	----------------------------	-----------------------------------

Technical data

Mechanical characteristics	
Maximum speed	6000 min ⁻¹ 1) at 60°C [140°F] 2500 min ⁻¹ 1)
Mass moment of inertia	< 220 x 10 ⁻⁶ kgm ² 2)
Starting torque with sealing at 20°C [68°F]	< 0.2 Nm
Load capacity of shaft	radial 200 N axial 100 N
Weight	approx. 0.8 kg [28.22 oz]
Protection acc. to EN 60529	IP65
Working temperature range	-40°C 3) ... +80°C [-40°F 3) ... +176°F]
Materials	shaft stainless steel, bore tolerance H7
Shock resistance acc. to EN 60068-2-27	2000 m/s ² , 6 ms
Vibration resistance acc. to EN 60068-2-6	100 m/s ² , 10 ... 2000 Hz

Electrical characteristics SinCos output		
Output circuit	SinCos U = 1 Vpp	SinCos U = 1 Vpp
Power supply	5 V DC (±5 %)	10 ... 30 V DC
Power consumption with inverted signal (no load)	typ. 65 mA max. 110 mA	typ. 65 mA max. 110 mA
-3 dB frequency	< 180 kHz	< 180 kHz
Signal level	channels A/B 1 Vpp (±20 %) channel 0 0.1 ... 1.2 V	1 Vpp (±20 %) 0.1 ... 1.2 V
Short circuit proof outputs 4)	yes	yes
Reverse polarity protection of the power supply	no	yes
UL approval	file 224618	
GL approval	letter of conformity No. 74130	
CE compliant acc. to	EMC guideline 2014/30/EU RoHS guideline 2011/65/EU	

Electrical characteristics RS422 / Push-pull

	RS422 (TTL compatible)	Push-pull	Push-pull (7272 compatible)
Output circuit			
Power supply	5 V DC (±5 %) 5 ... 30 V DC 10 ... 30 V DC	5 ... 30 V DC 10 ... 30 V DC	5 ... 30 V DC
Power consumption (no load)			
without inverted signal	–	typ. 55 mA/max. 125 mA	–
with inverted signal	typ. 40 mA/max. 90 mA	typ. 80 mA/max. 150 mA	typ. 50 mA/max. 100 mA
Permissible load / channel	max. +/- 20 mA	max. +/- 30 mA	max. +/- 20 mA
Pulse frequency	max. 300 kHz	max. 300 kHz	max. 300 kHz 5)
Signal level	HIGH min. 2.5 V LOW max. 0.5 V	min. +V – 3 V max. 2.5 V	min. +V – 2.0 V max. 0.5 V
Rising edge time t_r	max. 200 ns	max. 1 μs	max. 1 μs
Falling edge time t_f	max. 200 ns	max. 1 μs	max. 1 μs
Short circuit proof outputs 4)	yes	yes	yes
Reverse polarity protection of the power supply	no, 10 ... 30 V DC: yes	yes	no
UL approval	file 224618		
GL approval	letter of conformity No. 74130		
CE compliant acc. to	EMC guideline 2014/30/EU RoHS guideline 2011/65/EU		

1) During the run-in-phase of approx. 2 hours, reduce the limits for working temperature_{max} or speed max by 1/3.

2) Depending on shaft diameter.

3) With connector: -40°C [-40°F], securely installed: -30°C [-22°F], flexibly installed: -20°C [-4°F].

4) If power supply correctly applied.

5) Max. recommended cable length 30 m [98.43'].

Incremental encoders

Large hollow shaft robust, optical	A02H (hollow shaft)	Push-pull / RS422 / SinCos
-----------------------------------------------	----------------------------	-----------------------------------

Terminal assignment

Output circuit	Type of connection	Cable (isolate unused wires individually before initial start-up)											
1 ... D	1, A	Signal:	0 V	+V	0 Vsens	+Vsens	A	\bar{A}	B	\bar{B}	0	$\bar{0}$	\perp
		Core color:	WH	BN	GY PK	RD BU	GN	YE	GY	PK	BU	RD	shield
M23 connector, 12-pin													
1 ... D	2	Signal:	0 V	+V	0 Vsens	+Vsens	A	\bar{A}	B	\bar{B}	0	$\bar{0}$	\perp
		Pin:	10	12	11	2	5	6	8	1	3	4	PH ¹⁾
M12 connector, 8-pin													
1 ... D	E	Signal:	0 V	+V	0 Vsens	+Vsens	A	\bar{A}	B	\bar{B}	0	$\bar{0}$	\perp
		Pin:	1	2			3	4	5	6	7	8	PH ¹⁾
MIL connector, 10-pin													
1 ... D	D	Signal:	0 V	+V	0 Vsens	+Vsens	A	\bar{A}	B	\bar{B}	0	$\bar{0}$	\perp
		Pin:	F	D			A	G	B	H	C	I	J

- +V: Encoder power supply +V DC
- 0 V: Encoder power supply ground GND (0 V)
- 0 Vsens / +Vsens: Using the sensor outputs of the encoder, the voltage present can be measured and if necessary increased accordingly.
- A, \bar{A} : Incremental output channel A
- B, \bar{B} : Incremental output channel B
- 0, $\bar{0}$: Reference signal
- PH \perp : Plug connector housing (shield)

Top view of mating side, male contact base

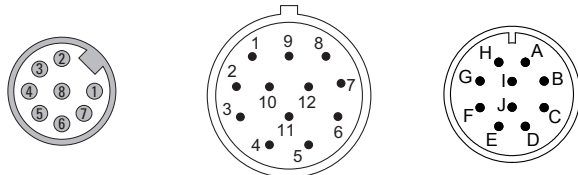

M12 connector, 8-pin

M23 connector, 12-pin

MIL connector, 10-pin

1) PH = shield is attached to connector housing.

Incremental encoders

Incremental encoders

Large hollow shaft
robust, optical

A02H (hollow shaft)

Push-pull / RS422 / SinCos

Dimensions hollow shaft version

Dimensions in mm [inch]

Flange without mounting aid Flange type 1

- 1 Recommended torque for the clamping ring 1.0 Nm
- B Cable version

D	Fit
20 [0.79]	H7
25 [0.98]	H7
28 [1.10]	H7
30 [1.18]	H7
38 [1.50]	H7
40 [1.57]	H7
42 [1.65]	H7
5/8"	H7
1"	H7
1 1/4"	H7

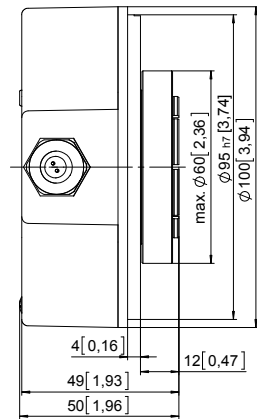
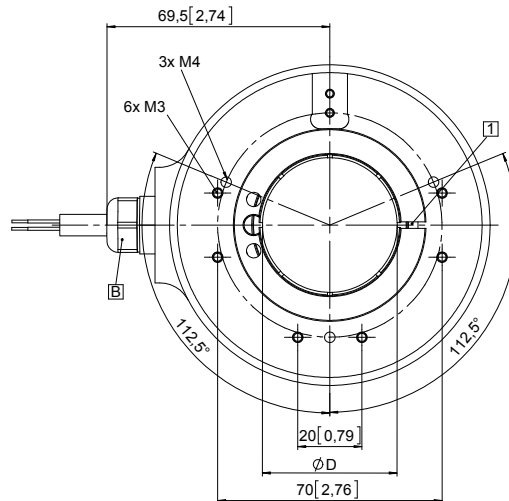

Flange with spring element Flange type 2 and 3

- 1 Spring element, short (flange type 2)
- 2 Spring element, long (flange type 3)
- 3 Recommended torque for the clamping ring
flange type 2: 1.0 Nm
flange type 3: 2.0 Nm
- B Cable version

D	Fit
20 [0.79]	H7
25 [0.98]	H7
28 [1.10]	H7
30 [1.18]	H7
38 [1.50]	H7
40 [1.57]	H7
42 [1.65]	H7
5/8"	H7
1"	H7
1 1/4"	H7

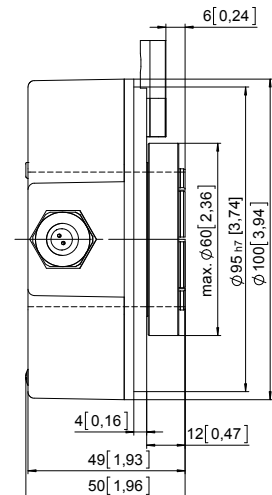
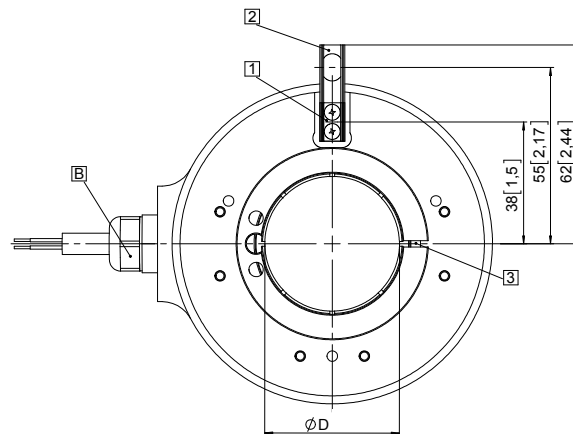

Mounting using the spring element, short

When mounting the encoder, ensure that dimension L is larger than the maximum axial play of the drive in the direction of the arrow.
Danger of mechanical seizure!

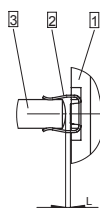

- 1 Flange
- 2 Spring element, short
- 3 Cylindrical pin

Mounting using the spring element, long

Cylindrical pin fed through the bore of the spring

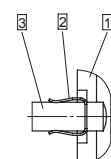

- 1 Flange
- 2 Spring element, long
- 3 Cylindrical pin

Incremental encoders

Large hollow shaft robust, optical	A02H (hollow shaft)	Push-pull / RS422 / SinCos
-----------------------------------------------	----------------------------	-----------------------------------

Dimensions hollow shaft version

Dimensions in mm [inch]

Flange with torque stop, long Flange type 5

- ③ Recommended torque for the clamping ring 2.0 Nm
- Ⓐ Plug version

D	Fit
20 [0.79]	H7
25 [0.98]	H7
28 [1.10]	H7
30 [1.18]	H7
38 [1.50]	H7
40 [1.57]	H7
42 [1.65]	H7
5/8"	H7
1"	H7
1 1/4"	H7

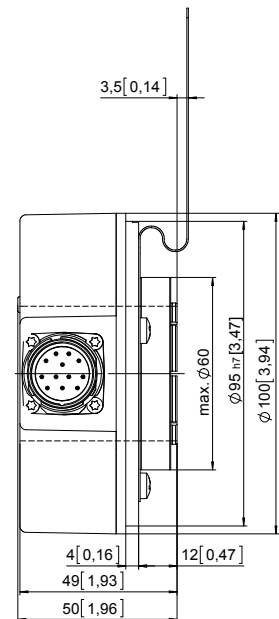
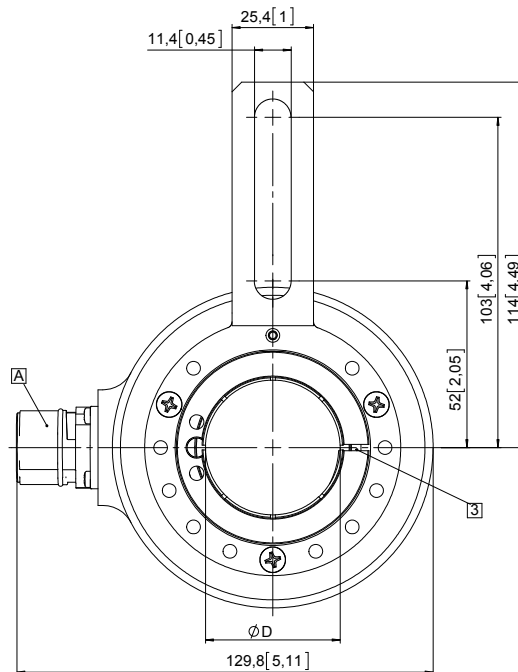

Flange with torque stop, short 4.5" Flange type 6

- ③ Recommended torque for the clamping ring 2.0 Nm
- Ⓐ Plug version

D	Fit
20 [0.79]	H7
25 [0.98]	H7
28 [1.10]	H7
30 [1.18]	H7
38 [1.50]	H7
40 [1.57]	H7
42 [1.65]	H7
5/8"	H7
1"	H7
1 1/4"	H7

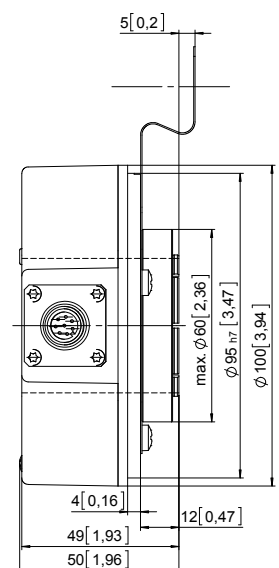
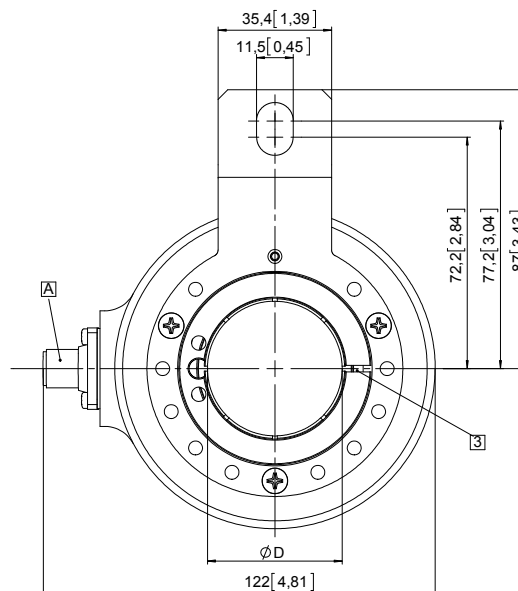

Incremental encoders